

minottiitalia

VO
LU
ME
1



CA
TA
LO
GO
GE
NER
A
LE

minottiitalia

IN DI CE IN DE X

248
ALTO

278
AMBROGIO

272
ANG

238
ARIA

154
ATOLLO

54
BARRA

228
BETTY

72
BROOKLYN

128
CANTO

208
CHIODO FISSO

166
CLEOPATRA

222
CONCRETE

138
DOROTEA

294
DRESSME

64
DUEDI

30
ESSENZA DI FORMOSA

266
EXTRA

26
FORMOSA ACCUCCIATA

22
FORMOSA ADAGIATA

26
FORMOSA APPOGGIATA

18
FORMOSA DISTESA

12
FORMOSA IN PIEDI

252
FRAGILE

80
FULLMOON

32
GESSOLINA

244
KING

300
KM

88
LADY

88
MAN

290
METEORE

196
MIMI'

160
NYC

234
ODE

284
PEPITE

160
PISA

180
PONTIANA

44
PUNTO

65
QUATTRODI

242
QUEENS

100
REBUS

118
RIFLESSO D'ONDA

146
SAMURAI

188
SHORE

172
SPECCHIO

54
TASTO

202
TIMPANO

62
TREDI

258
TRI

308
TUBI

108
WINDOWS

316
DATI TECNICI
TECHNICAL DATA

CONTENITORI STORAGE



12
FORMOSA IN PIEDI



30
ESSENZA DI FORMOSA

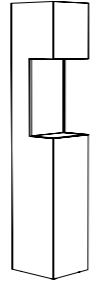

100
REBUS

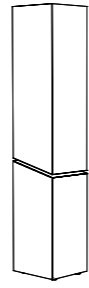

146
SAMURAI

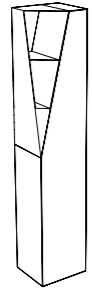

242
QUEENS

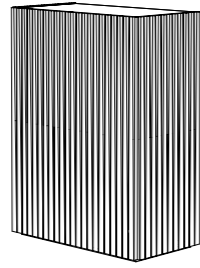

138
DOROTEA

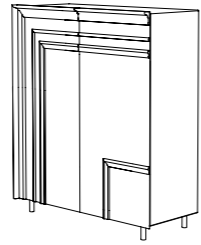

42
GESSOLINA

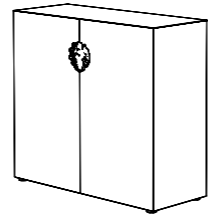

244
KING

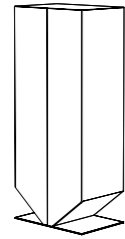

202
TIMPANO

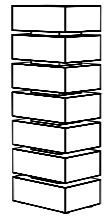

160
NYC

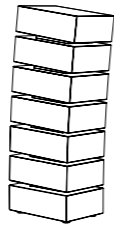

161
PISA

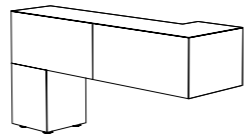

22
FORMOSA ADAGIATA

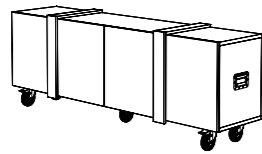

252
FRAGILE

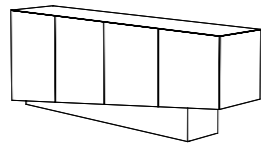

266
EXTRA

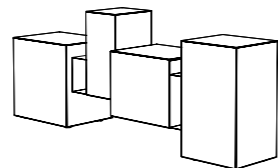

72
BROOKLYN

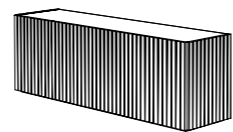

140
DOROTEA

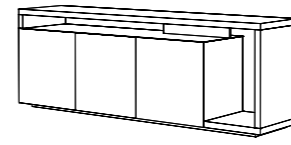

238
ARIA

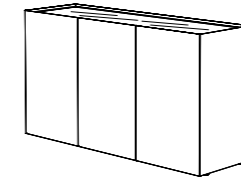

300
KM

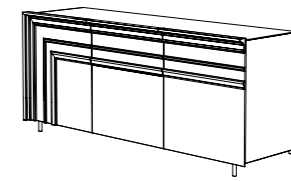

40
GESSOLINA

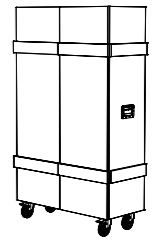

248
ALTO



88
LADY

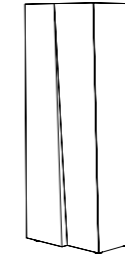

88
MAN

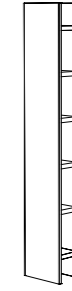

278
AMBROGIO

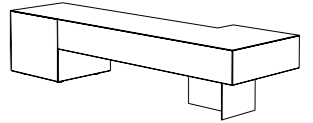

18
FORMOSA DISTESA

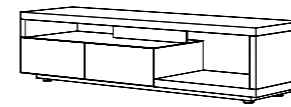

236
ODE

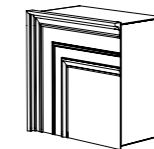

32
GESSOLINA

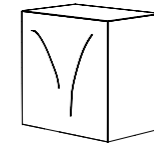

118
RIFLESSO D'ONDA

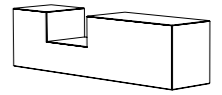

62
TREDI'

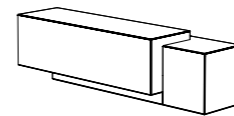

188
SHORE

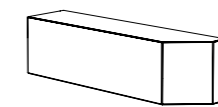

128
CANTO

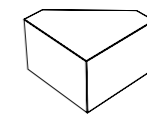

272
ANG

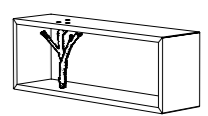

258
TRI

AP
PEN
DI
ABI
TI
HA
NG
ER
S



228
BETTY



278
AMBROGIO



284
PEPITE

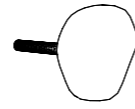

290
METEORE

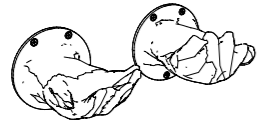

196
MIMI'

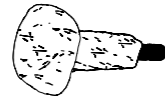

208
CHIODOFISSO



213
CHIODOFISSO 50



212
CHIODOFISSO 85

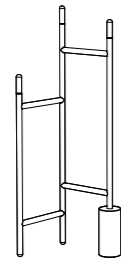

294
DRESSME

SP
EC
CHI
MIR
RO
RS

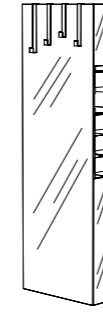

228
BETTY



278
AMBROGIO



213
CHIODOFISSO 50

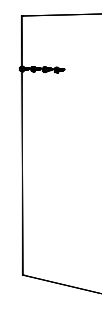

212
CHIODOFISSO 85

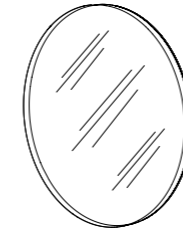

80
FULLMOON

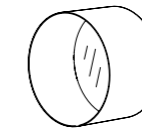

44
PUNTO

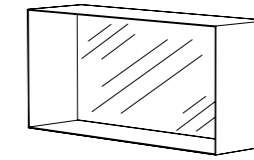

54
BARRA

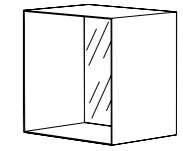

54
TASTO

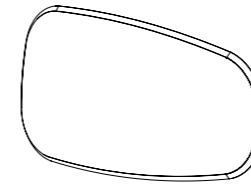

172
SPECCHIO

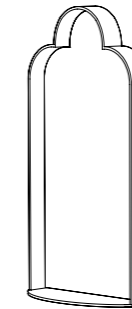

108
WINDOWS

LIBRERIE
BOOK SHELVES



30
ESSENZA DI FORMOSA

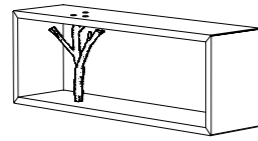

258
TRI

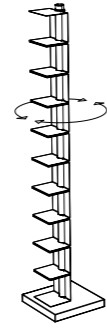

106
CLEOPATRA

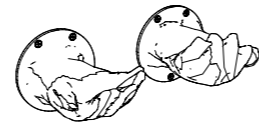

136
MIMI'

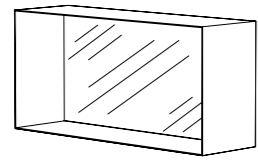

54
BARRA

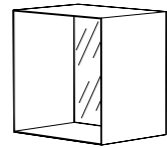

54
TASTO

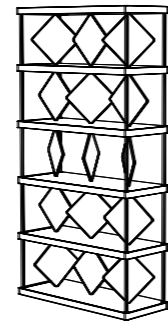

180
PONTIANA

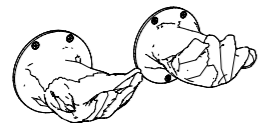

136
MIMI'

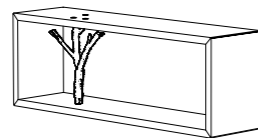

258
TRI

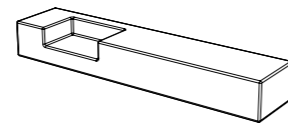

222
CONCRETE

MENSOLE
SHELVES

COMODINI
BEDSIDE TABLES

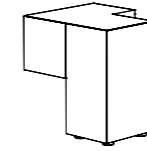

27
FORMOSA APPOGGIATA

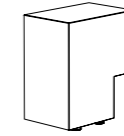

26
FORMOSA ACCUCCIATA

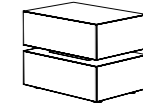

160
NYC

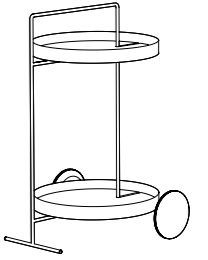

154
ATOLLO

TAVOLI
TABLES

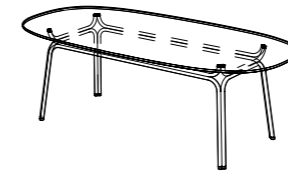

308
TUBI

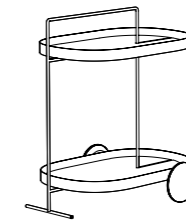

154
ATOLLO

SIS
TE
MI
TV
SYS
TE
M

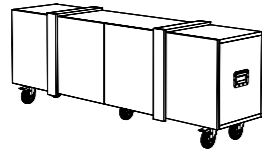

252
FRAGILE

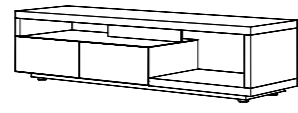

234
ODE

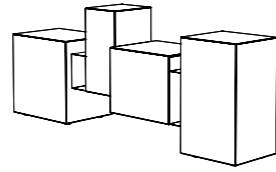

72
BROOKLYN

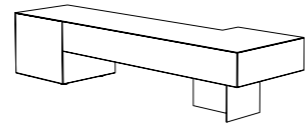

18
FORMOSA DISTESA

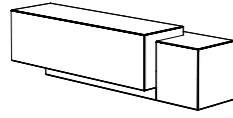

188
SHORE

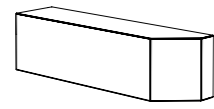

128
CANTO

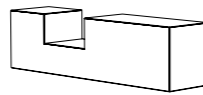

62
TREDI'

FORMOSA

DHS



FO
RMO
SA IN
PIE
DI

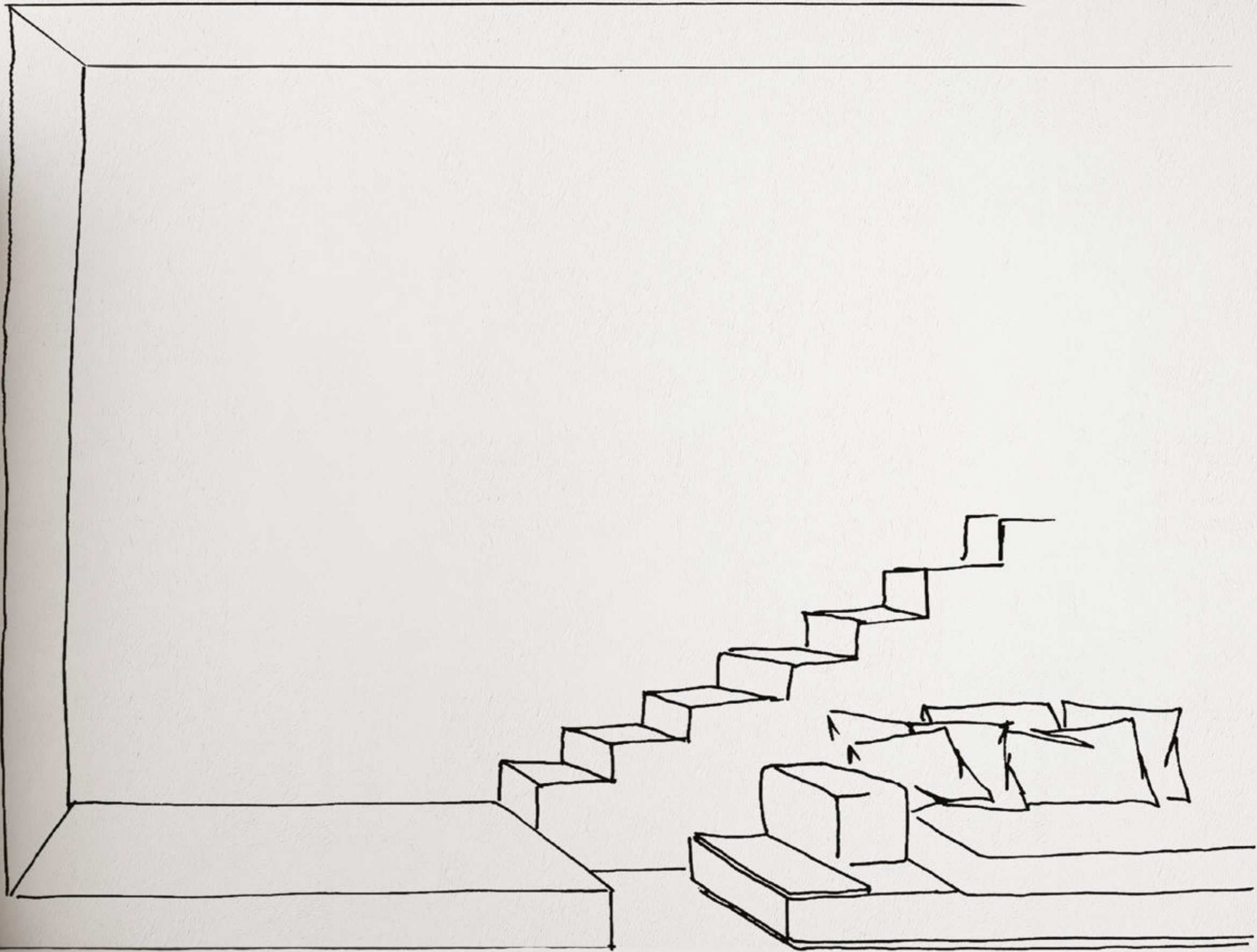

FORMOSA
IN
PIEDI

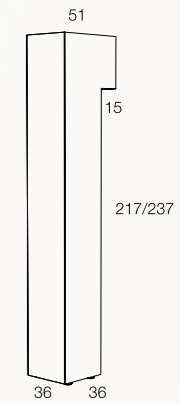

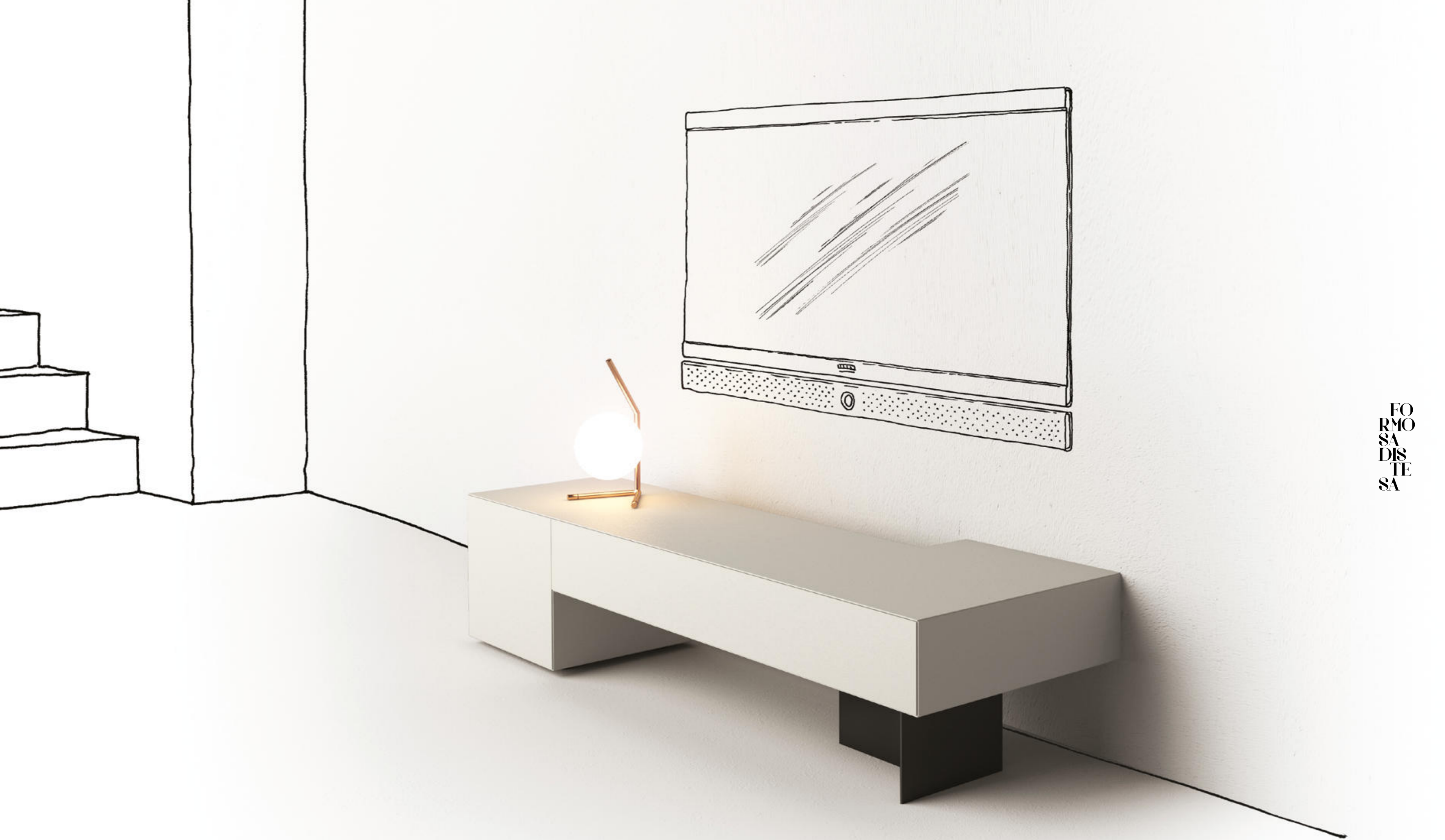

FO
RMO
SA
DIS
TE
SA

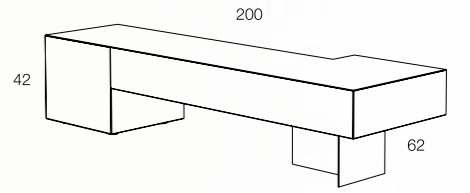

FO
RMO
SA
ADA
GIA
TA



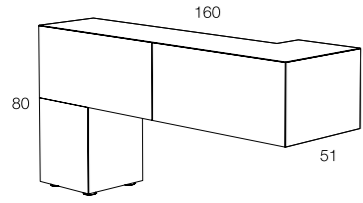

FO
RMO
SA
ADA
GIA
TA





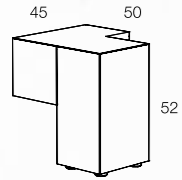

FO
RMO
SA
APP
OG
GIA
TA

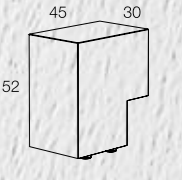
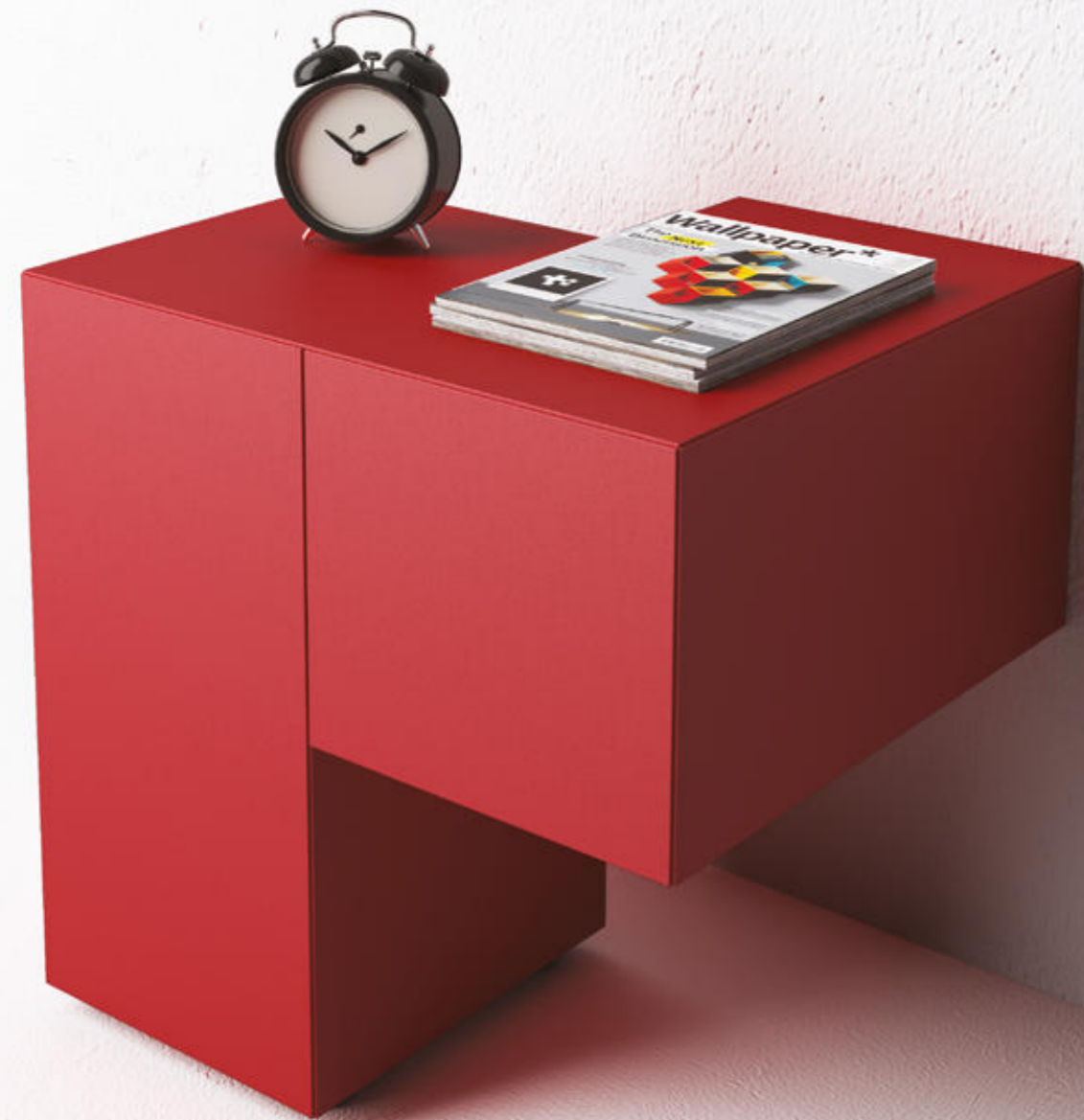

FO
RMO
SA
ACC
UC
CIA
TA



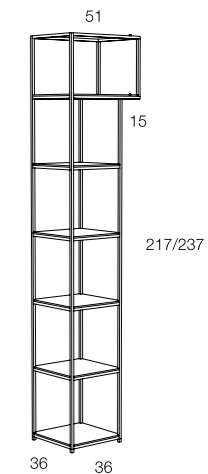

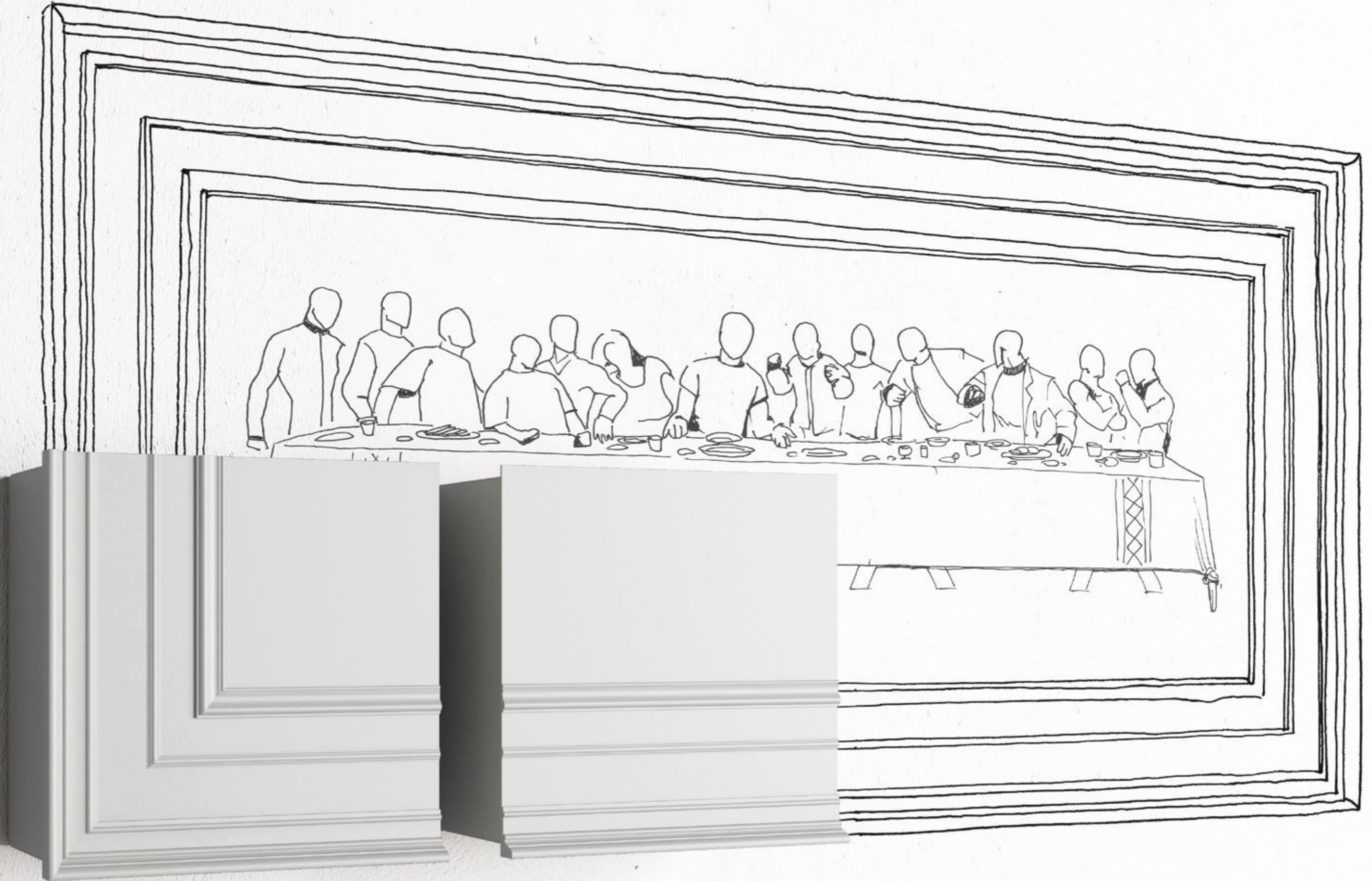

GES
SO
LI
NA

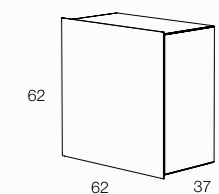
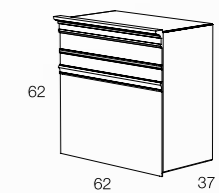
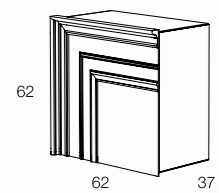

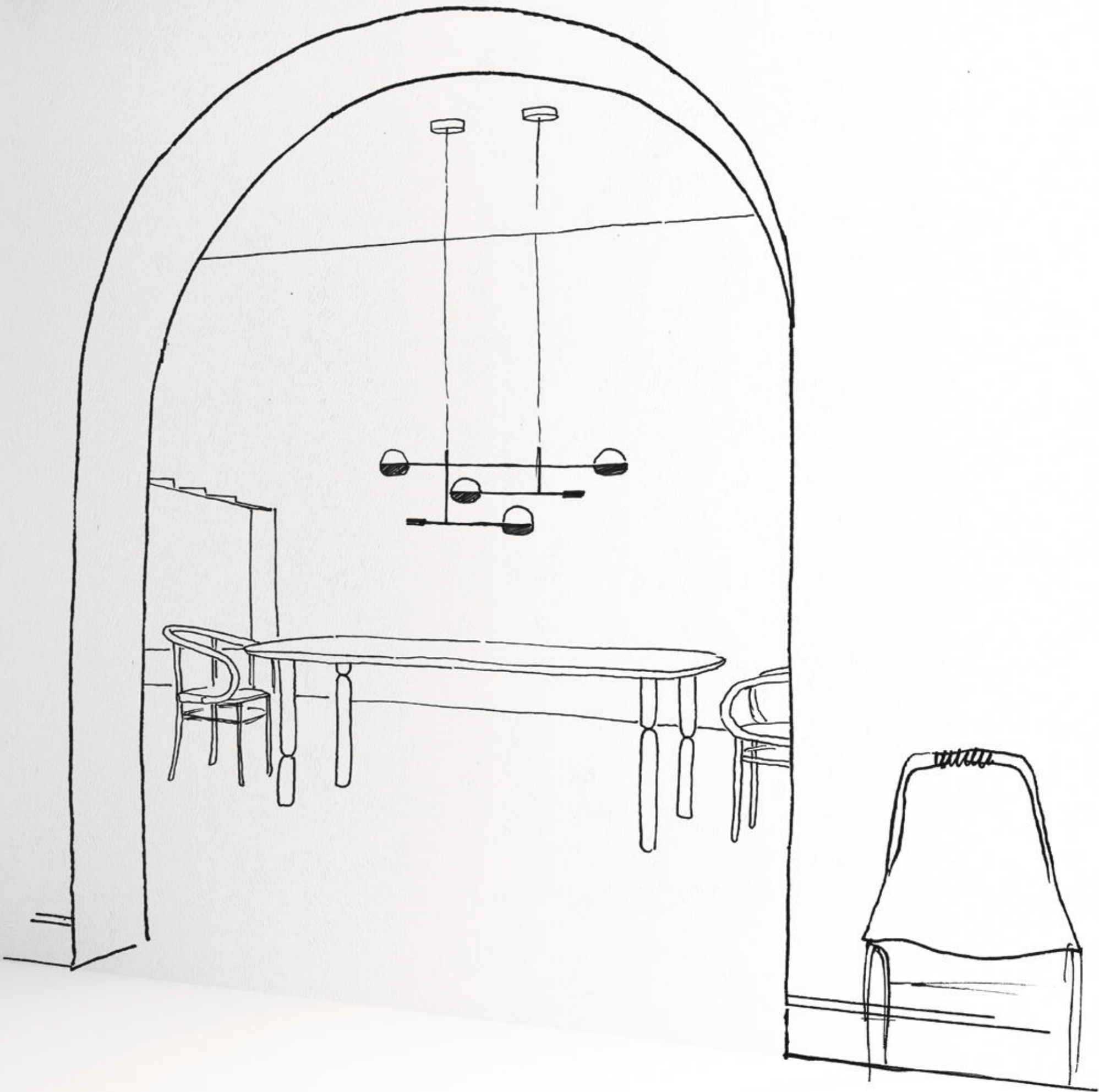



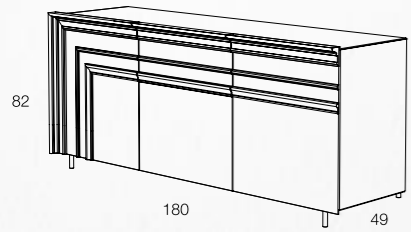

GES
SO
LI
NA



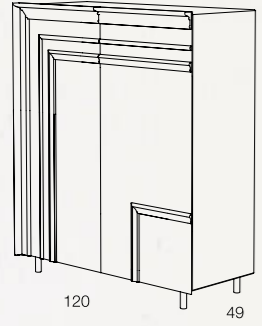

GES
SO
LI
NA



PUN TO BAR RA TAS TO

CLAUDIO BITETTI



PUN
TO

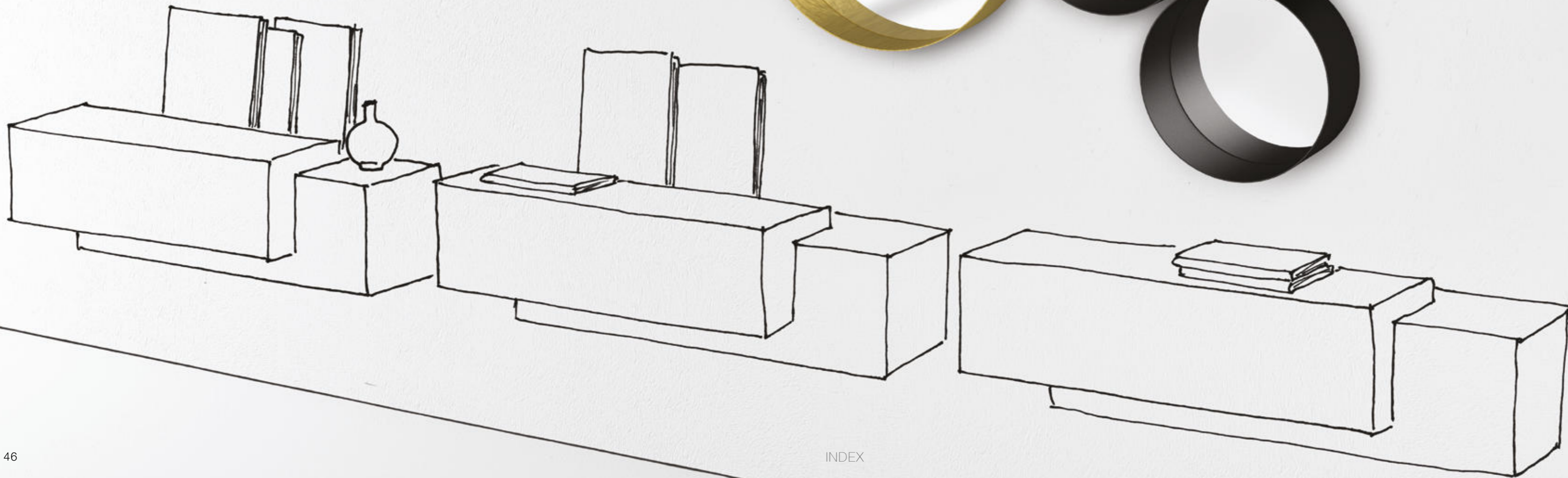
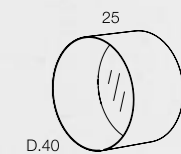
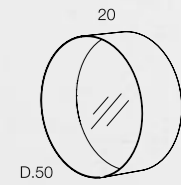
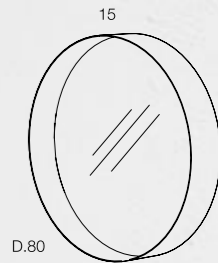
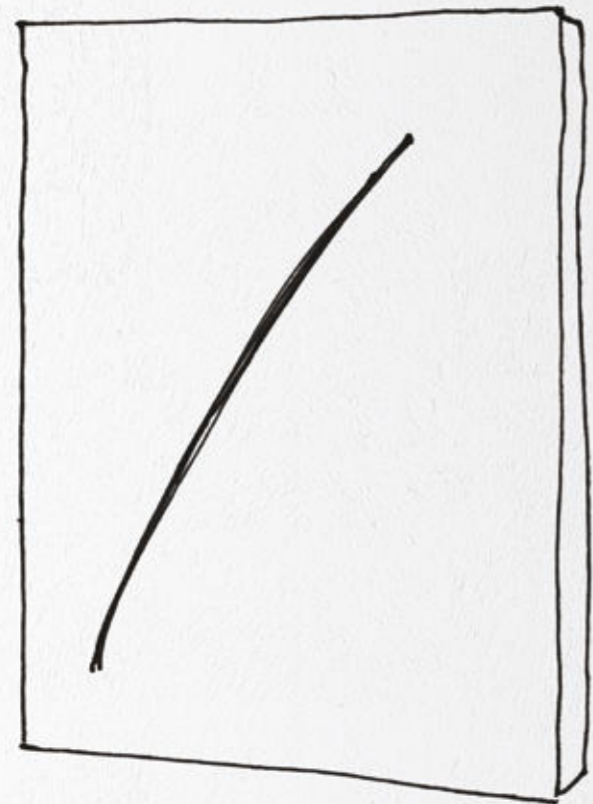

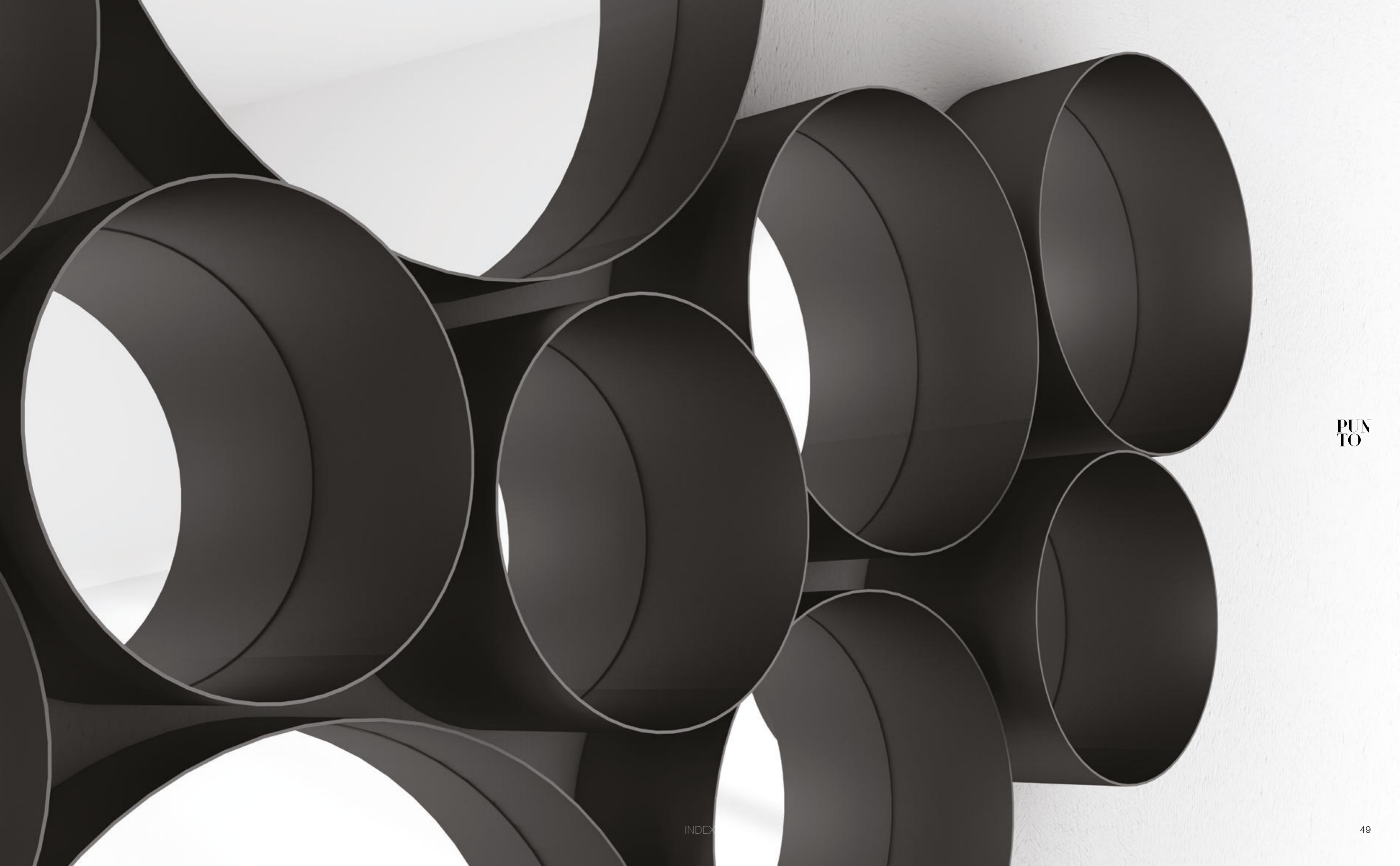

PUN
TO

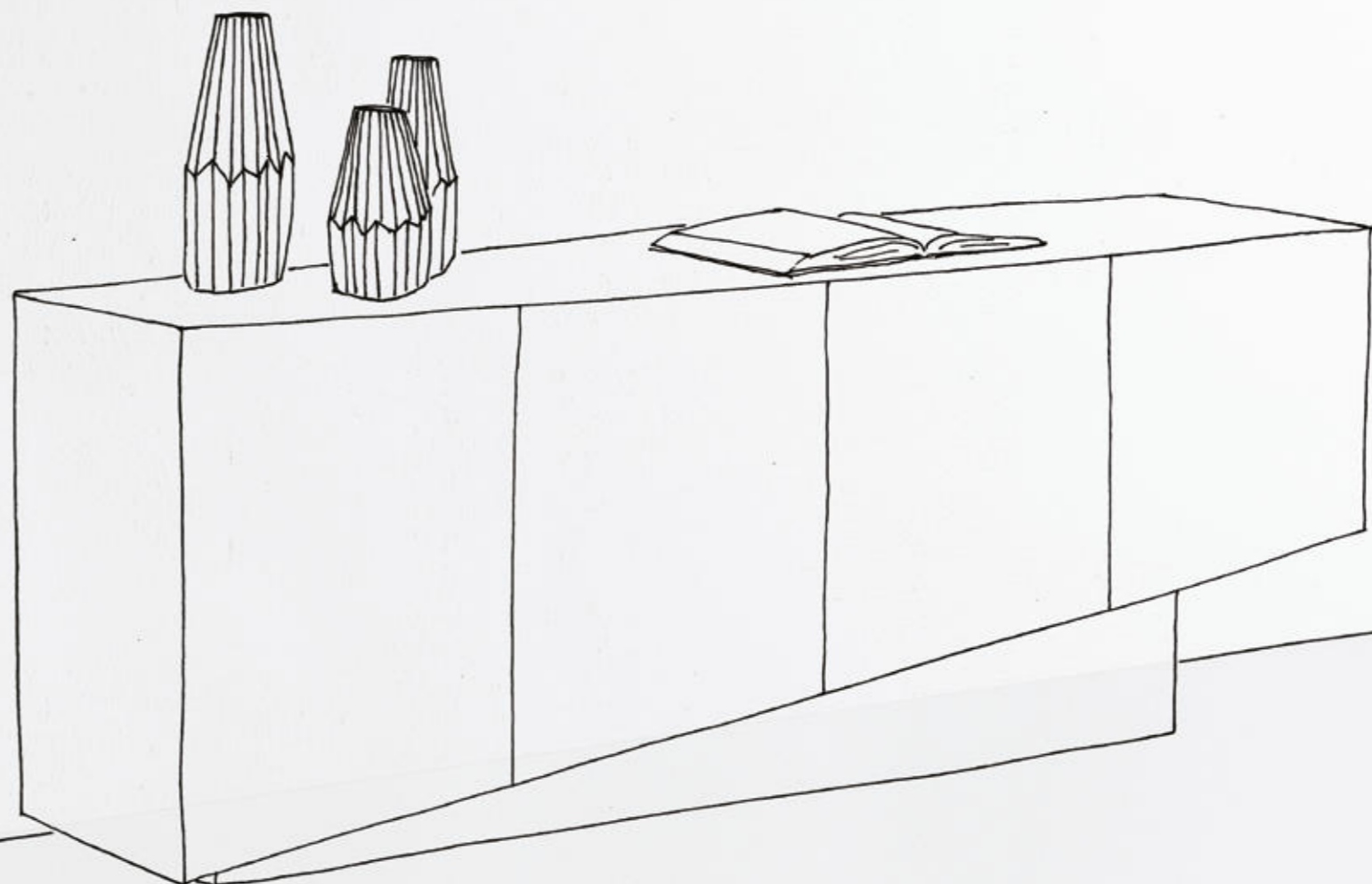
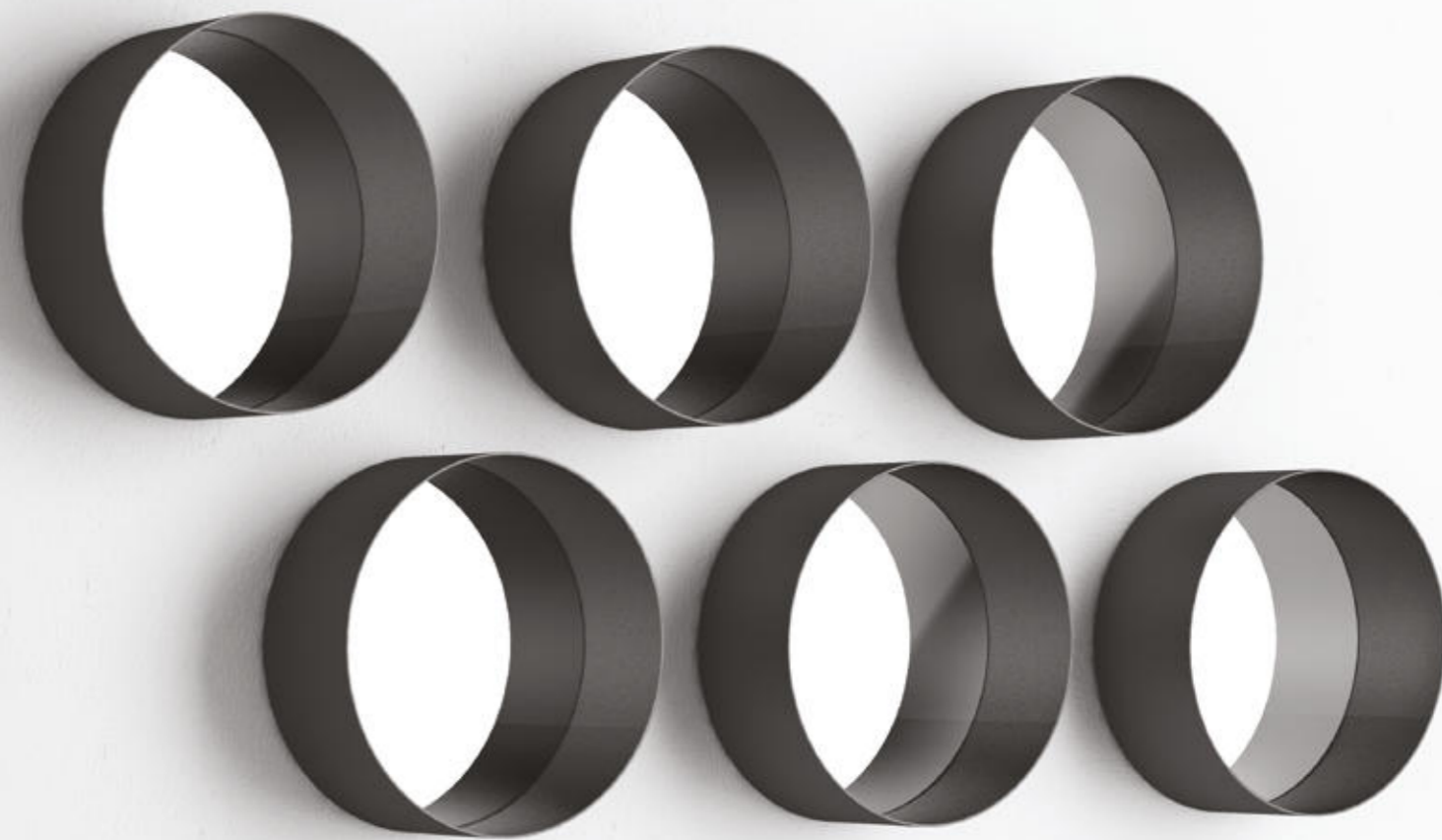

PUN
TO

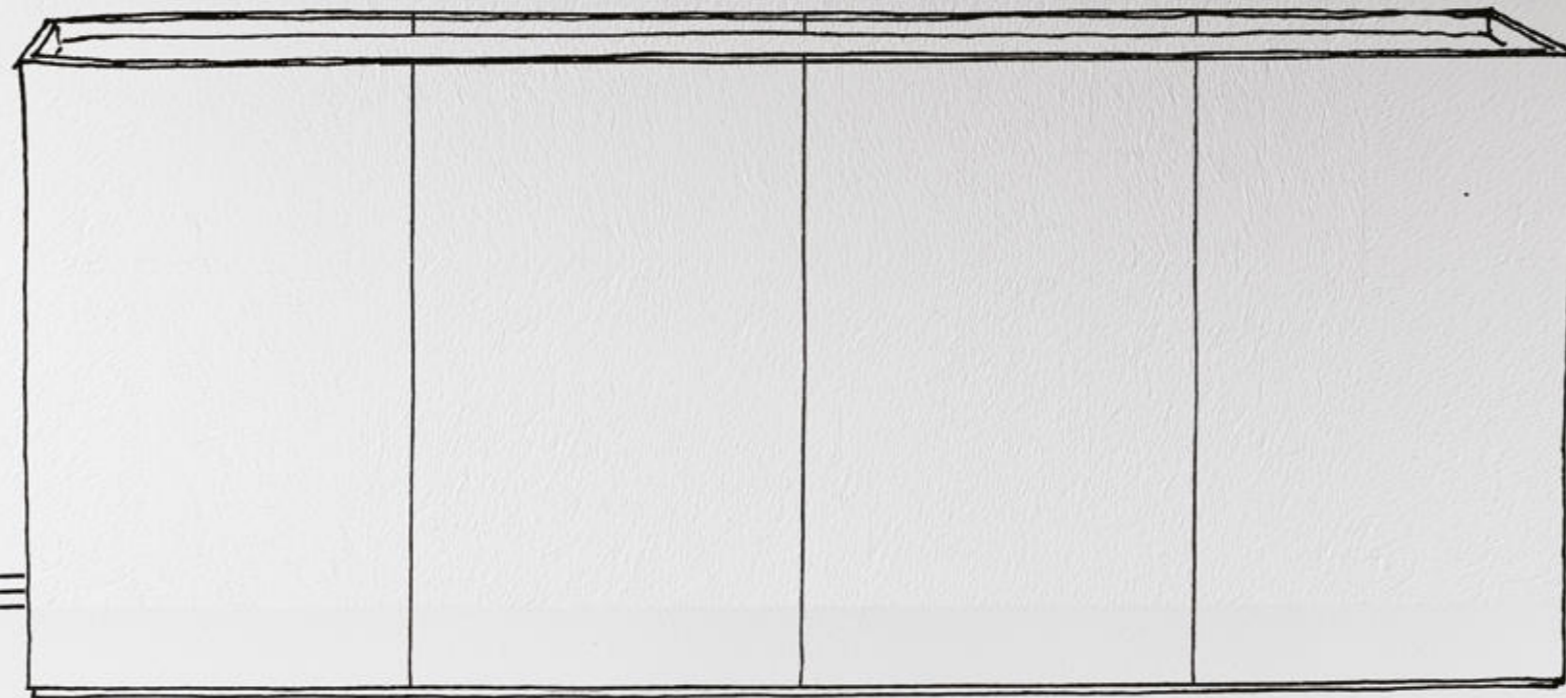
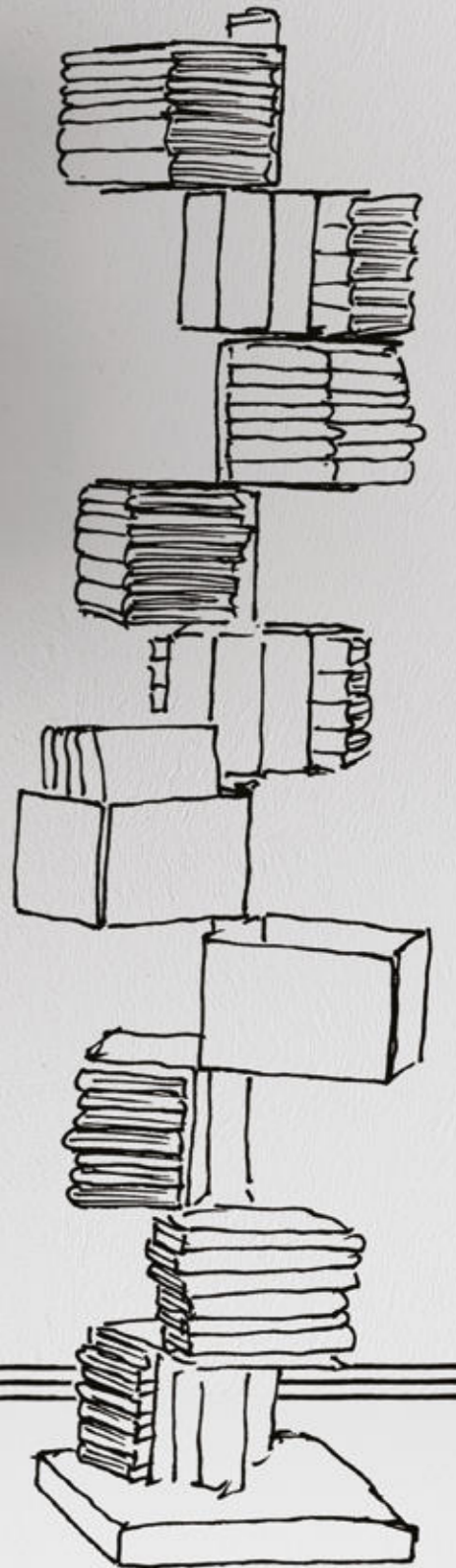

TASTO

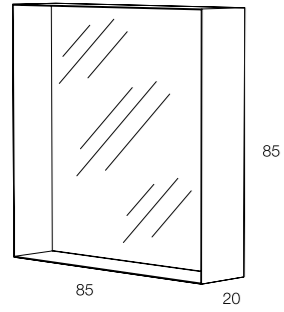
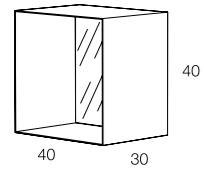

BARRA

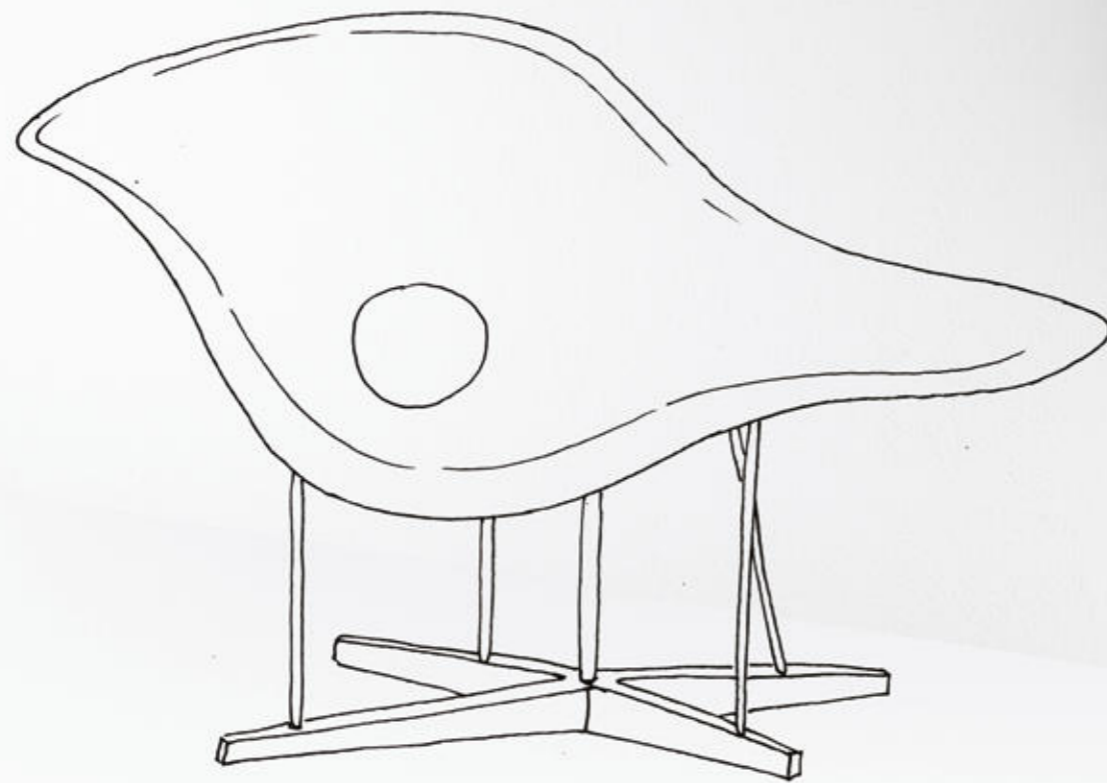
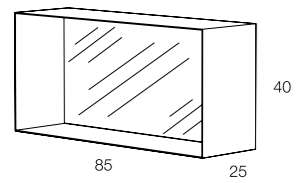
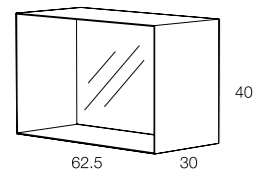

BAR
RA
TAS
TO

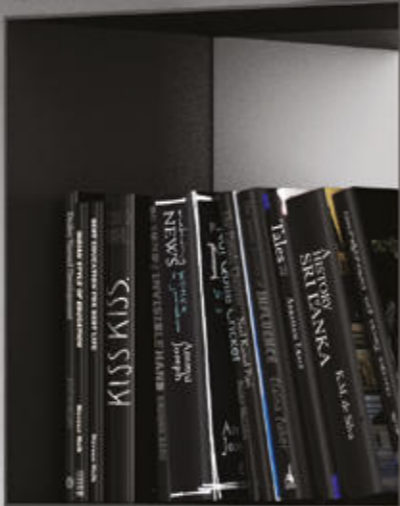
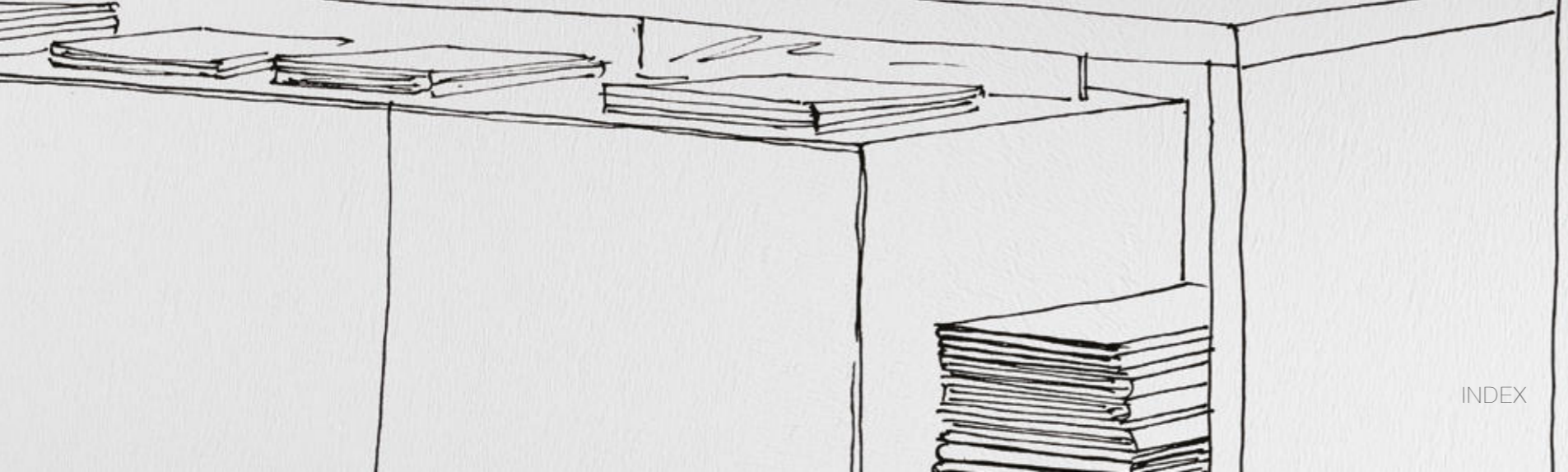



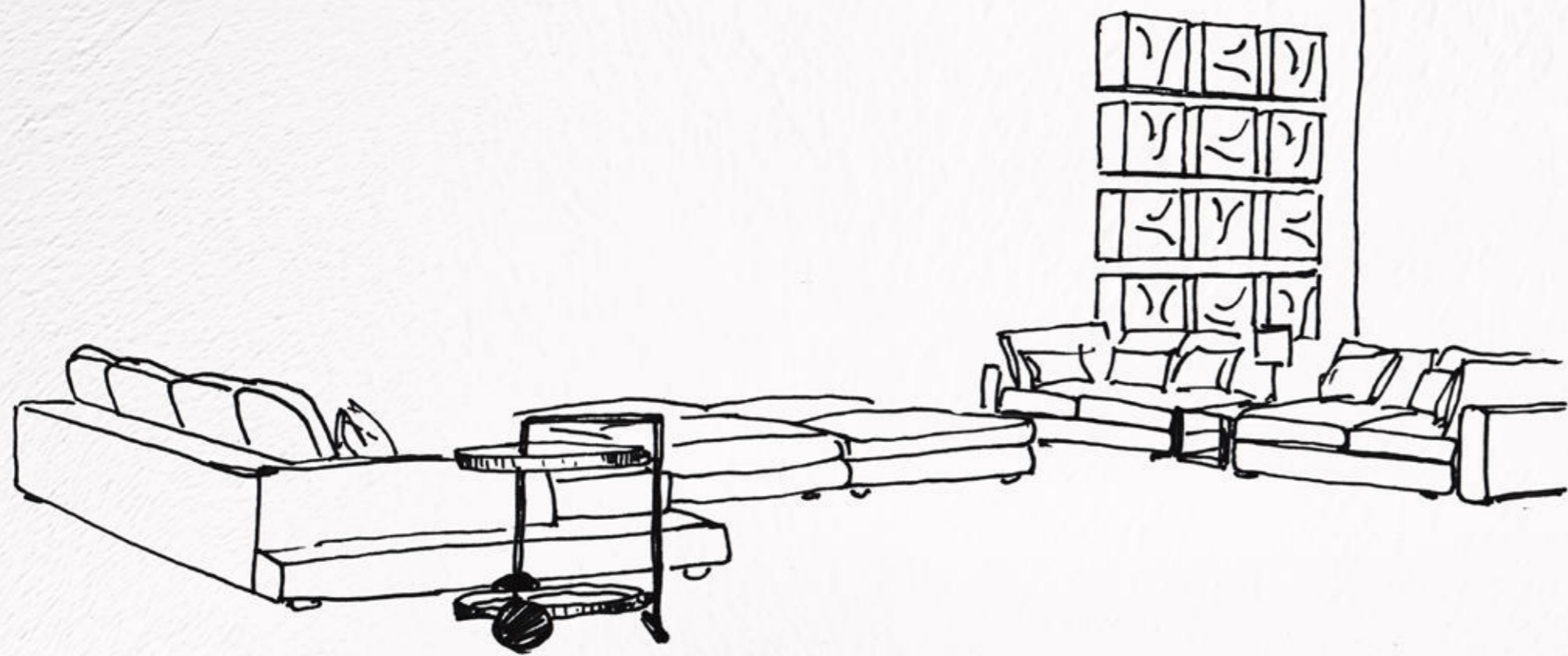



DU
E
DI
TR
EDI
QU
ATT
RO
DI

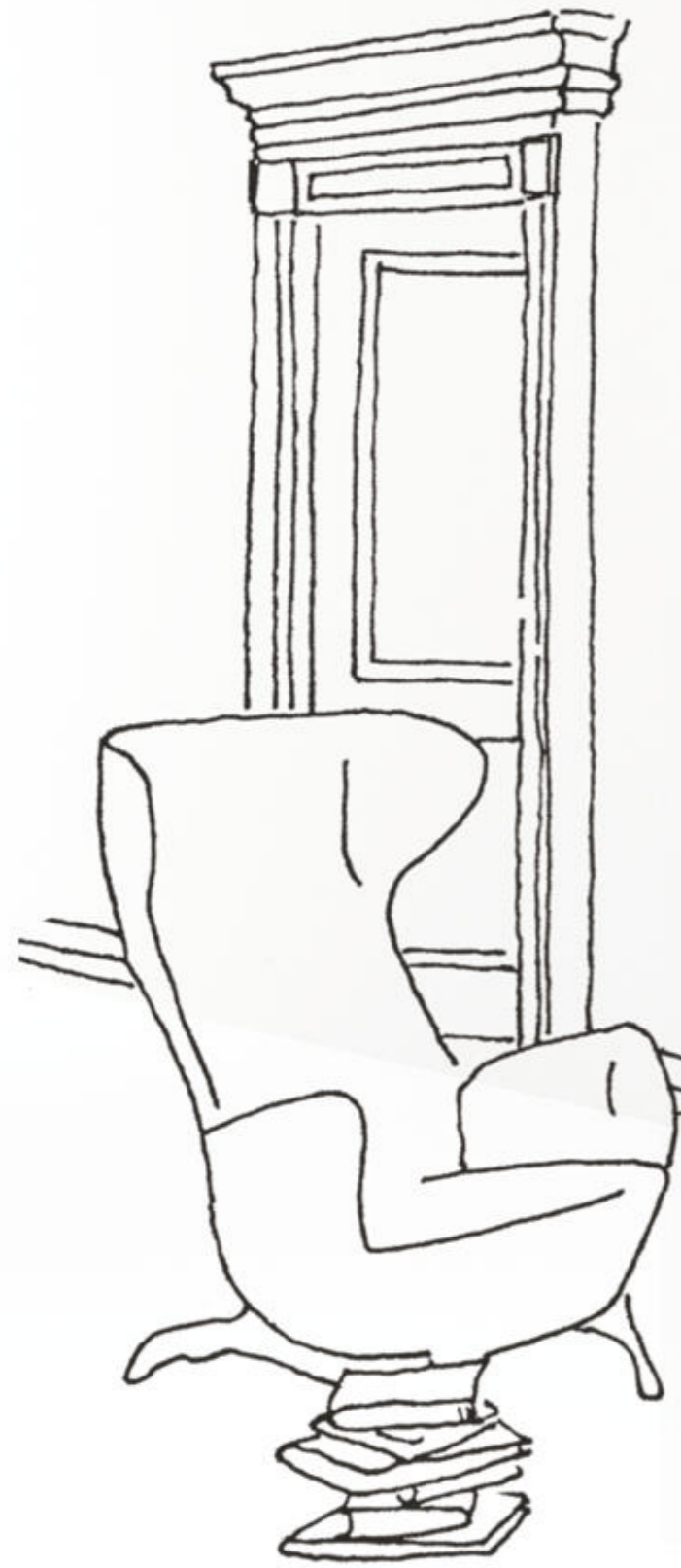

TR
EDI



DUEDI

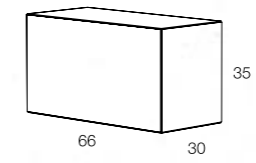

TREDI

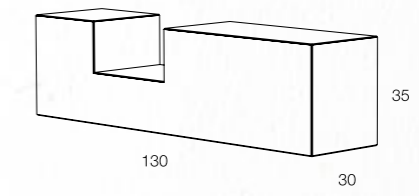

QUATTRODI

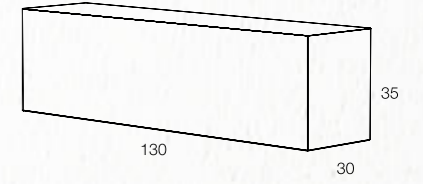



TR
EDI

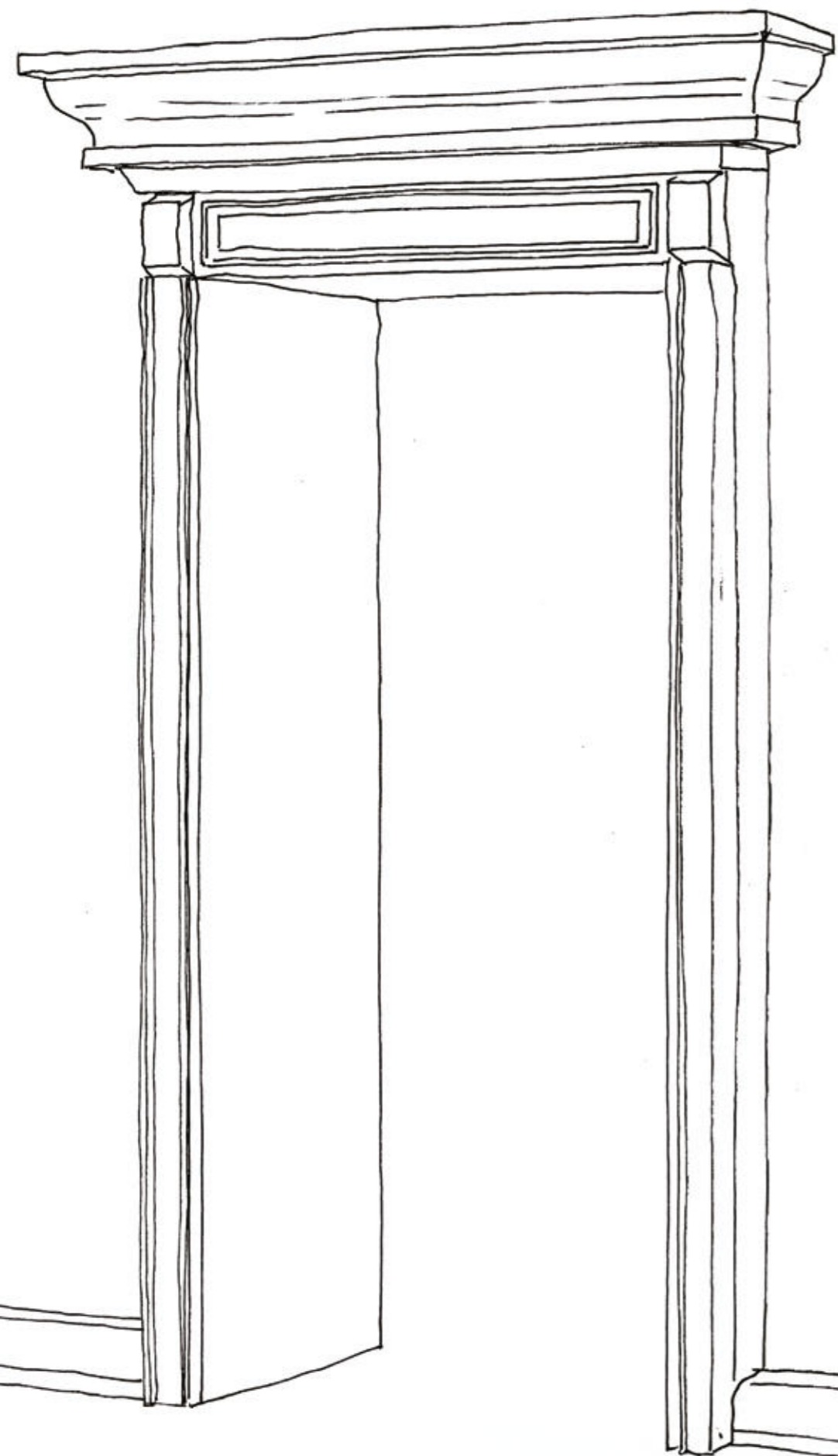

TR
EDI

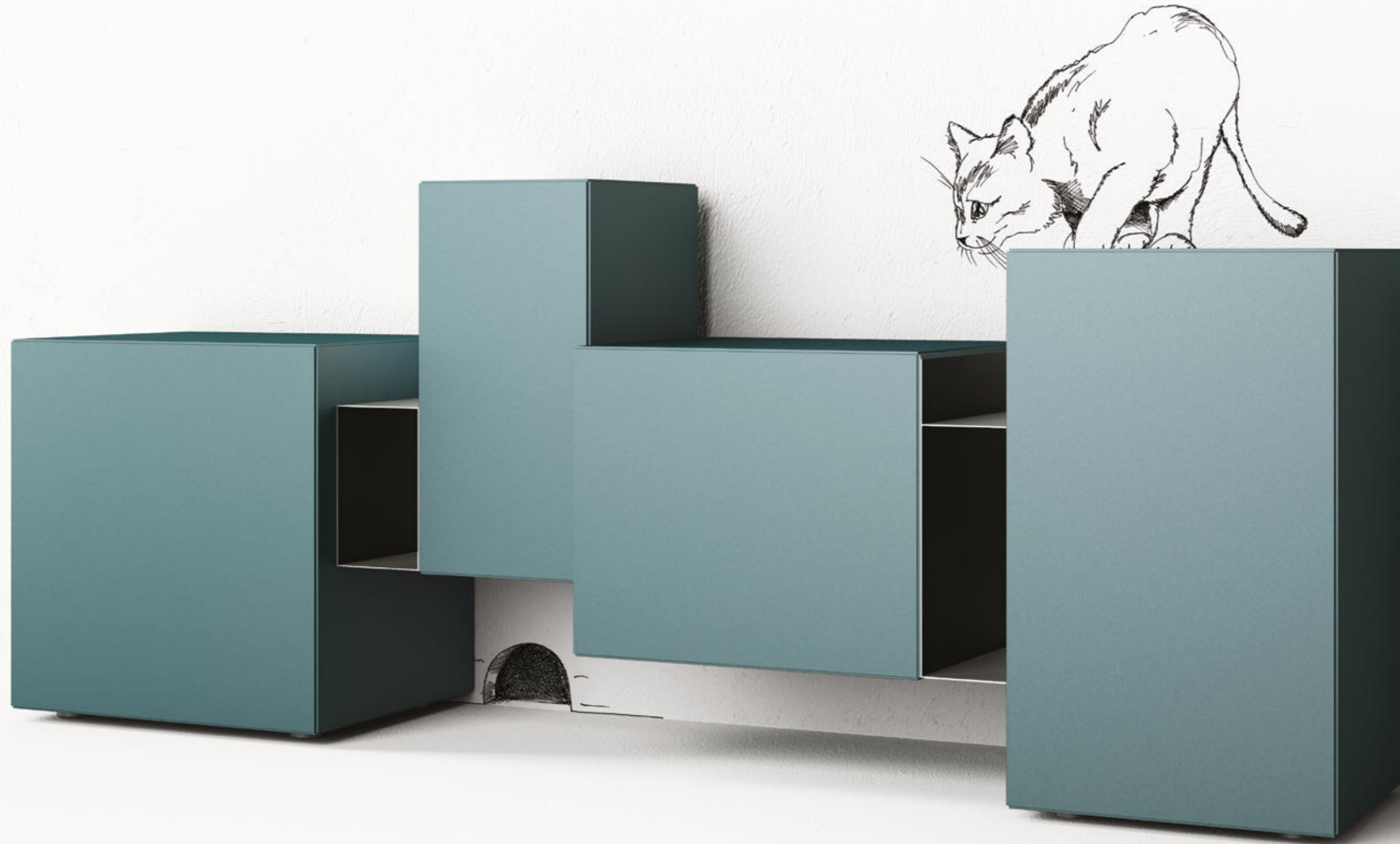

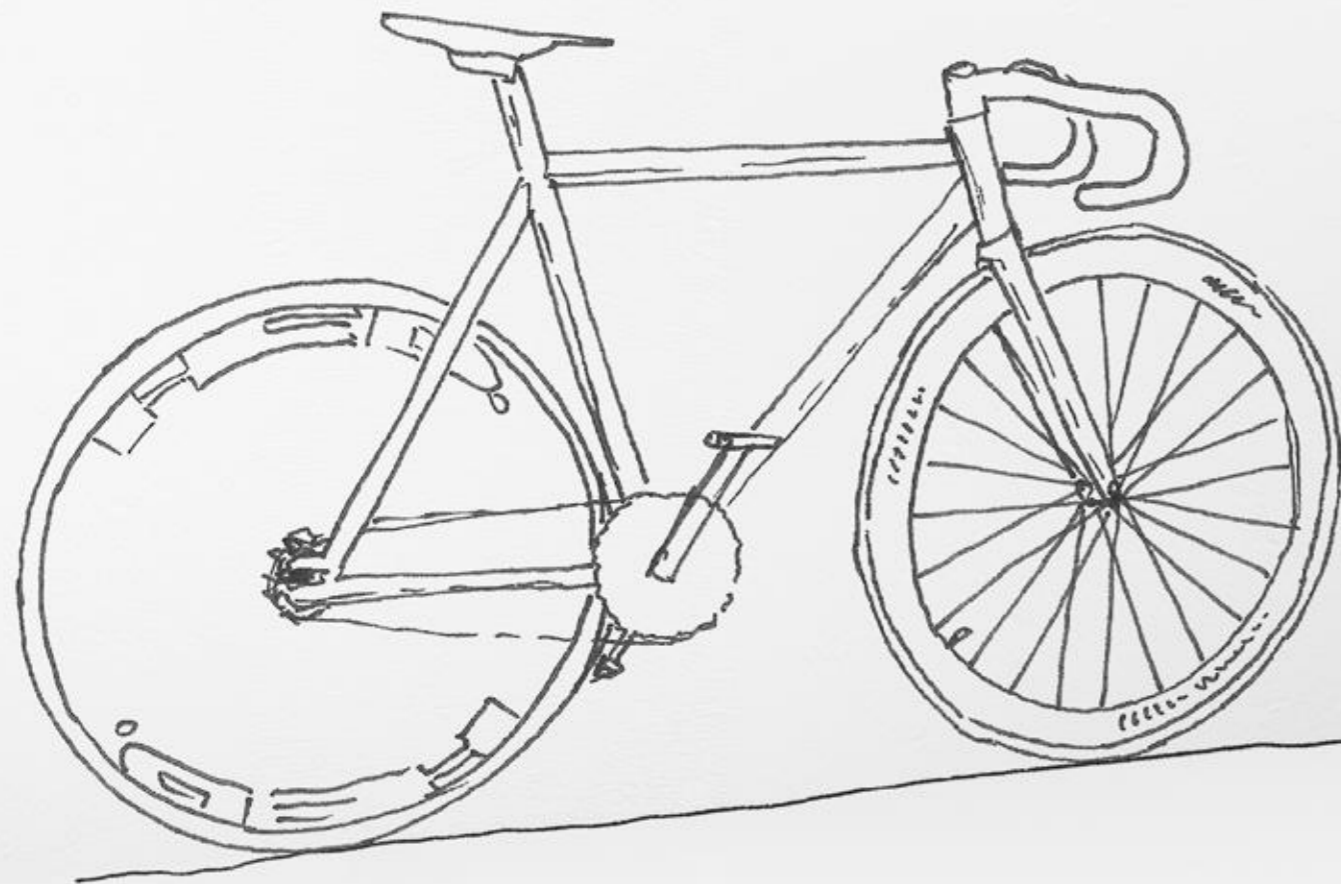

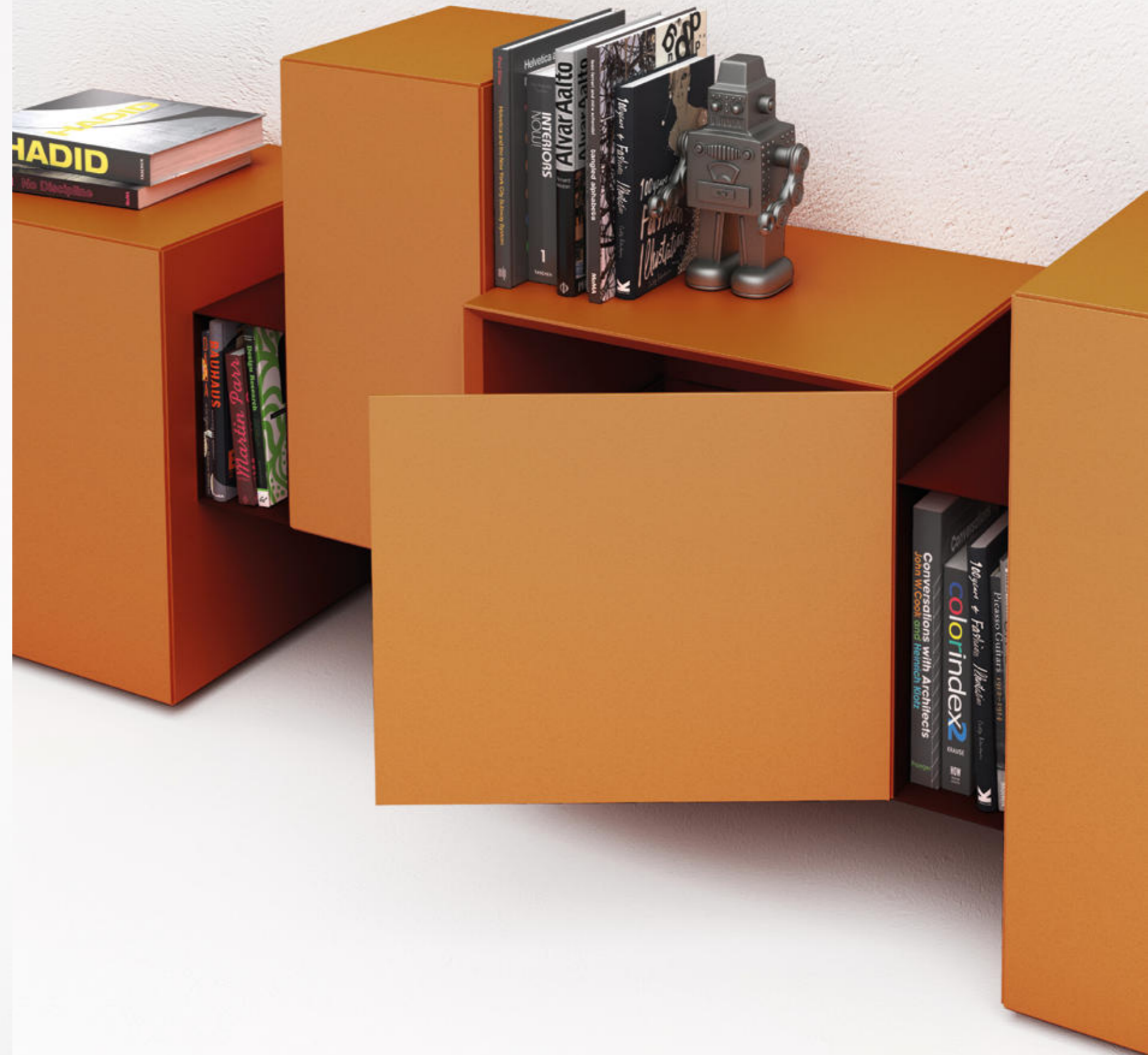
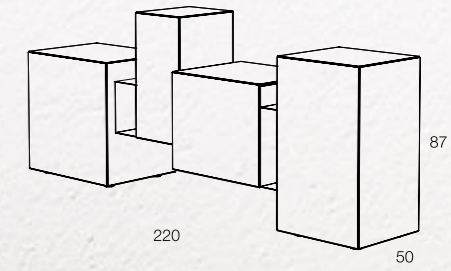
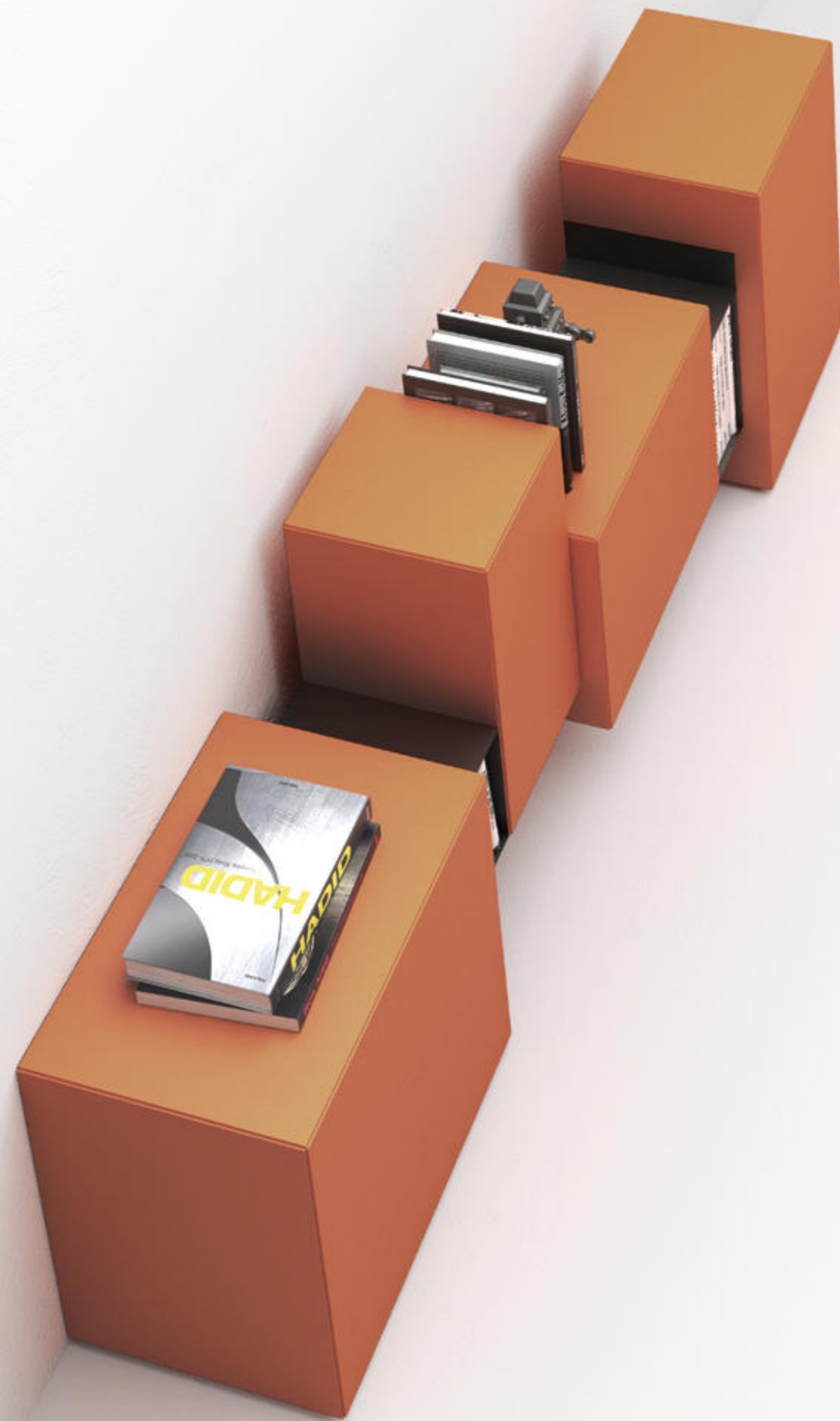



FULLMOON

DSH



INDEX

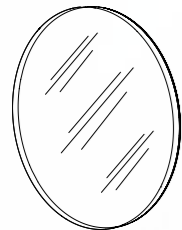

D.130
D.150

FU
LMO
ON

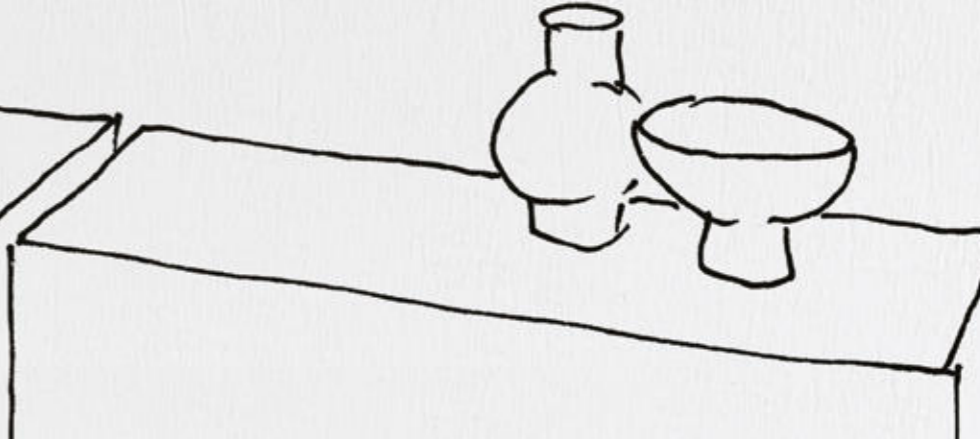
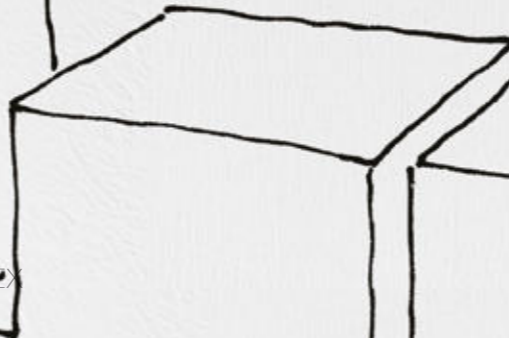
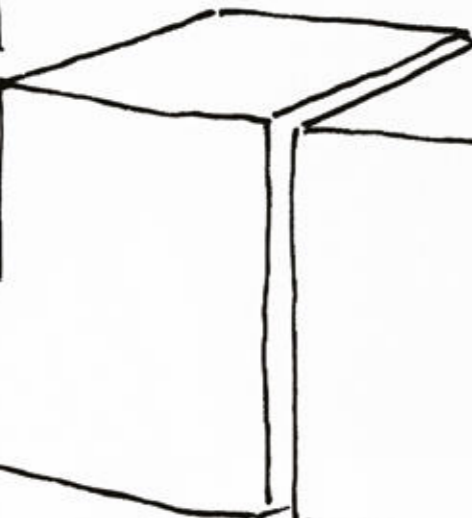
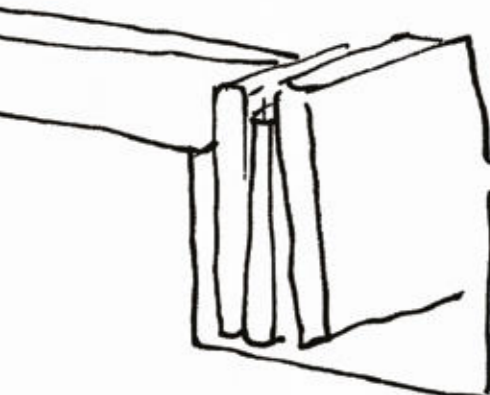
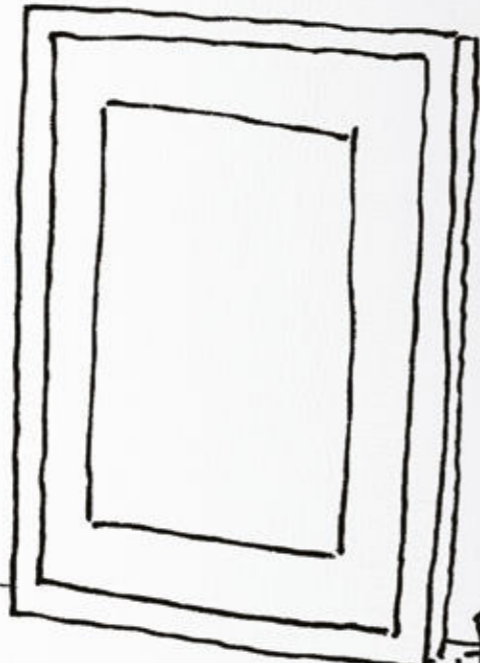
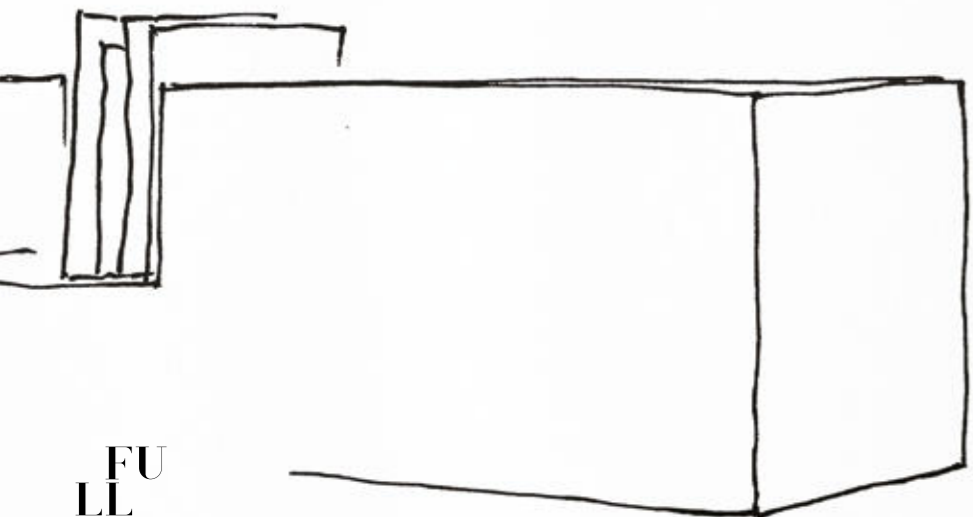





L A D Y & M A N N

CLAUDIO LOVADINA

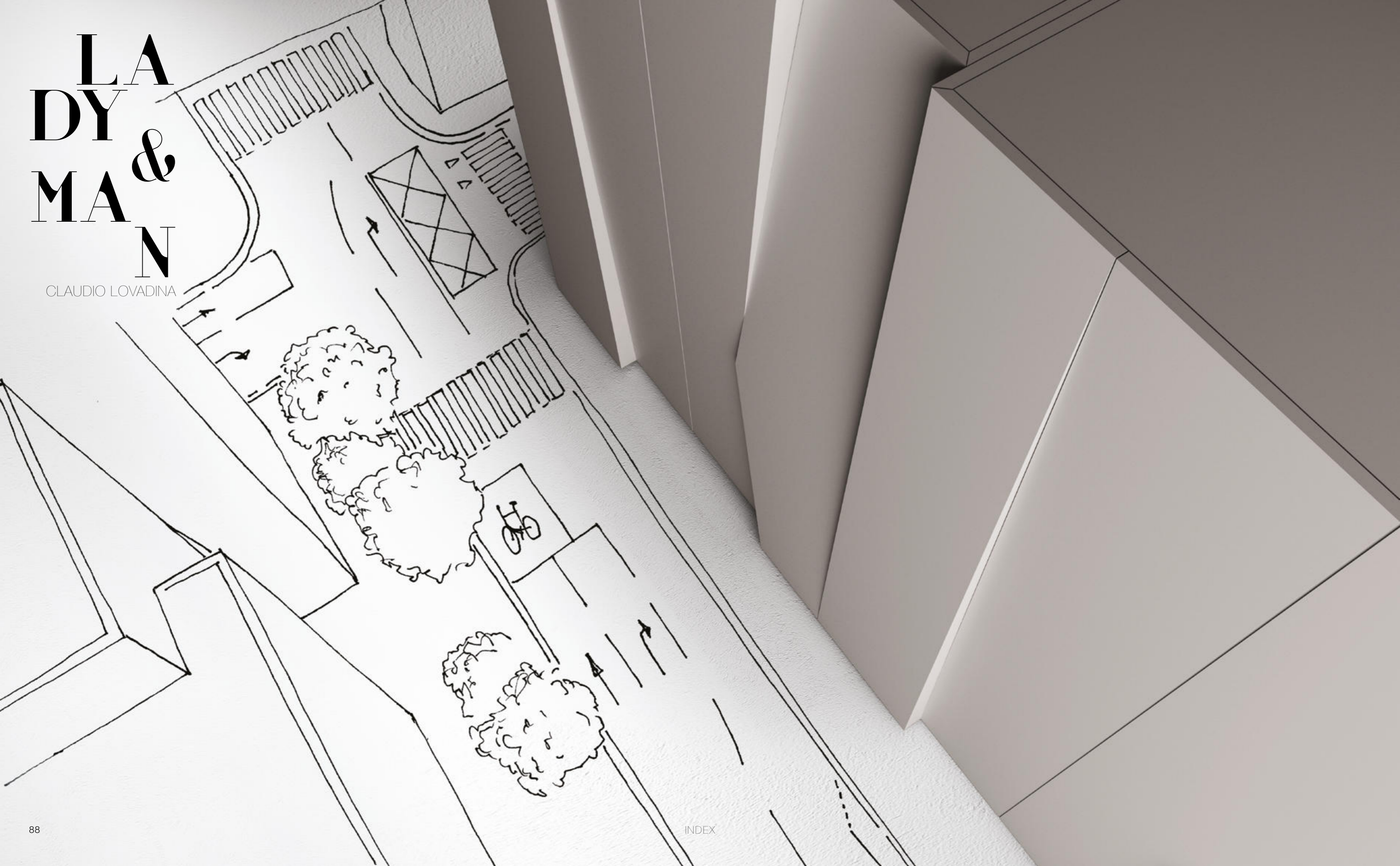

LADY

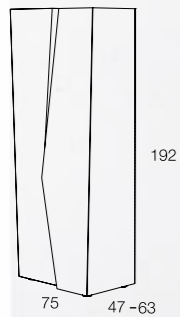

MAN

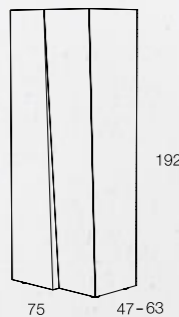

LADY & MAN



L
A
D
Y

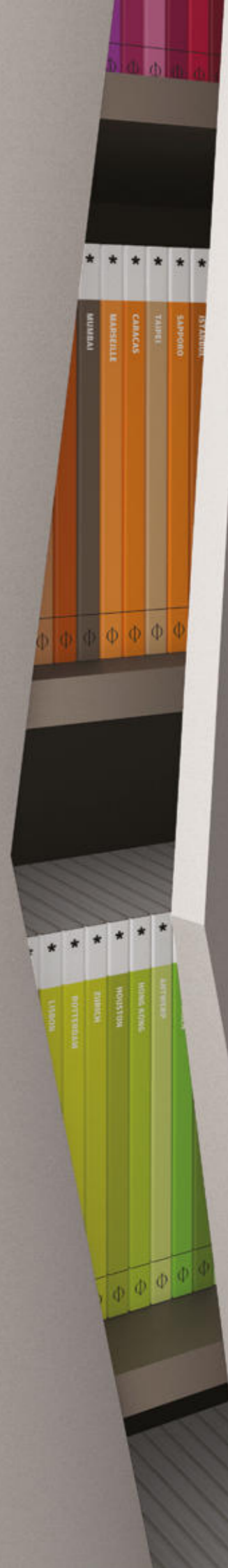

MAN





LADY &
MAN

INDEX

RE BUS

CLAUDIO BITETTI

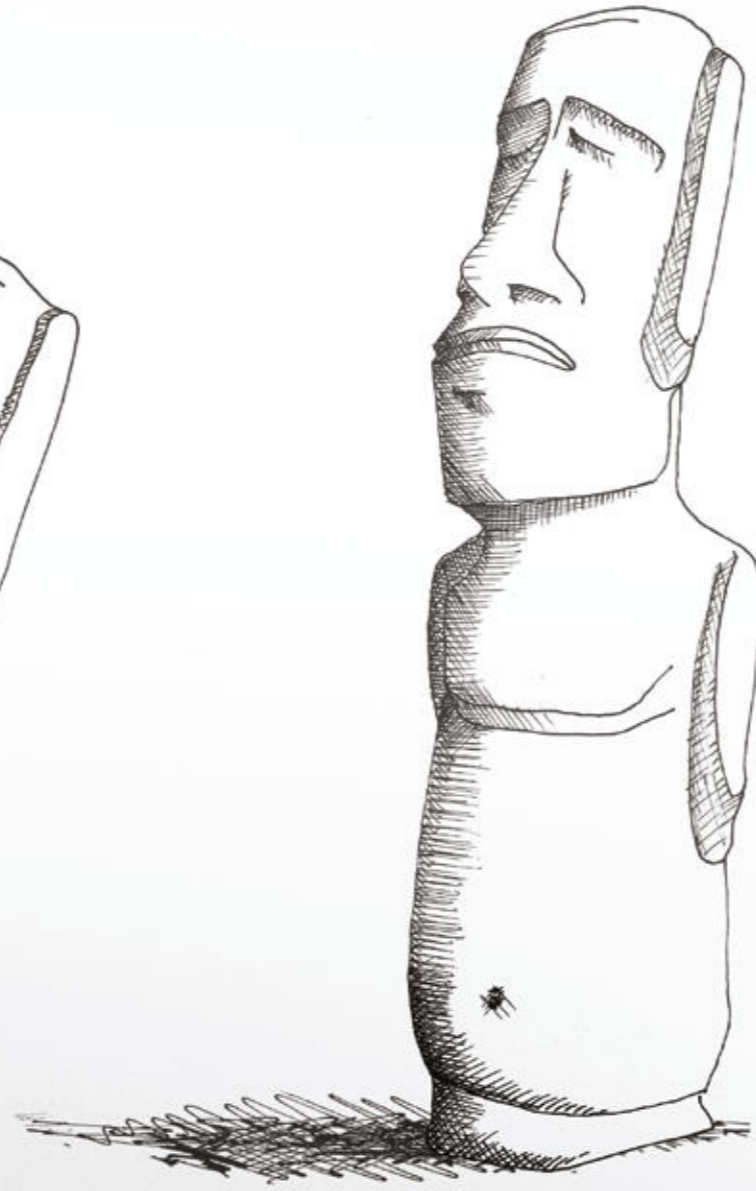
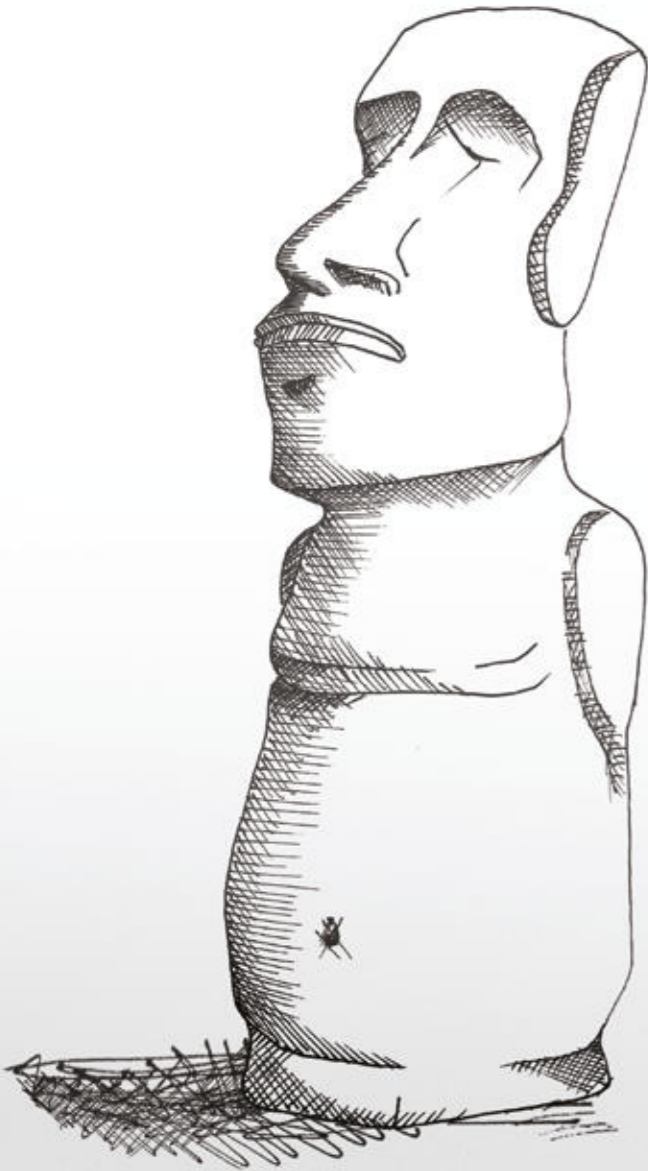



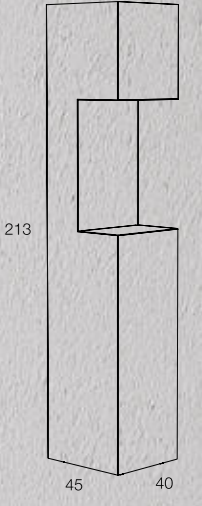

RE
BUS

RE
BUS



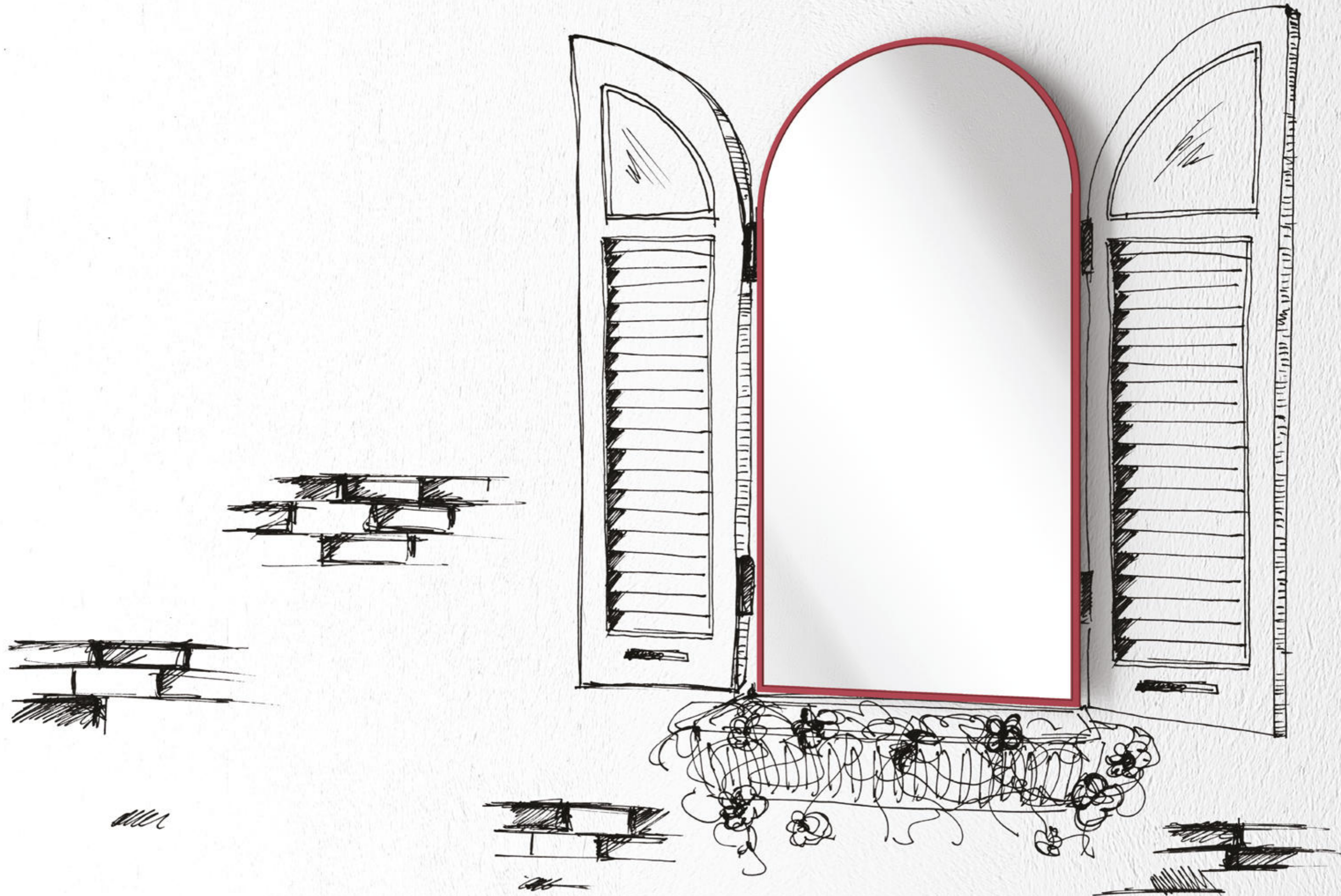

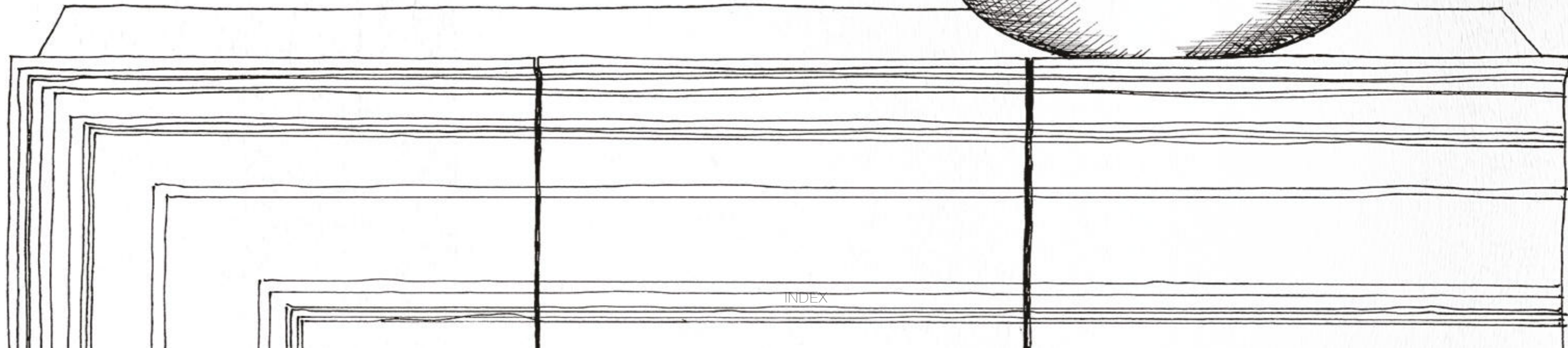

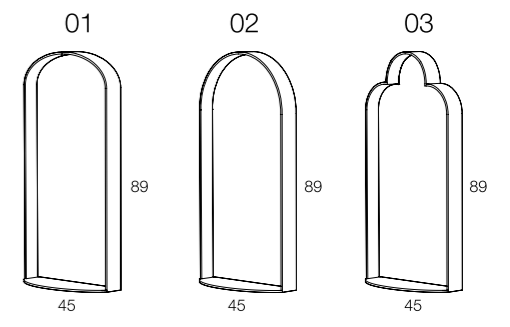

WI
NDO
WS



WI
NDO
WS

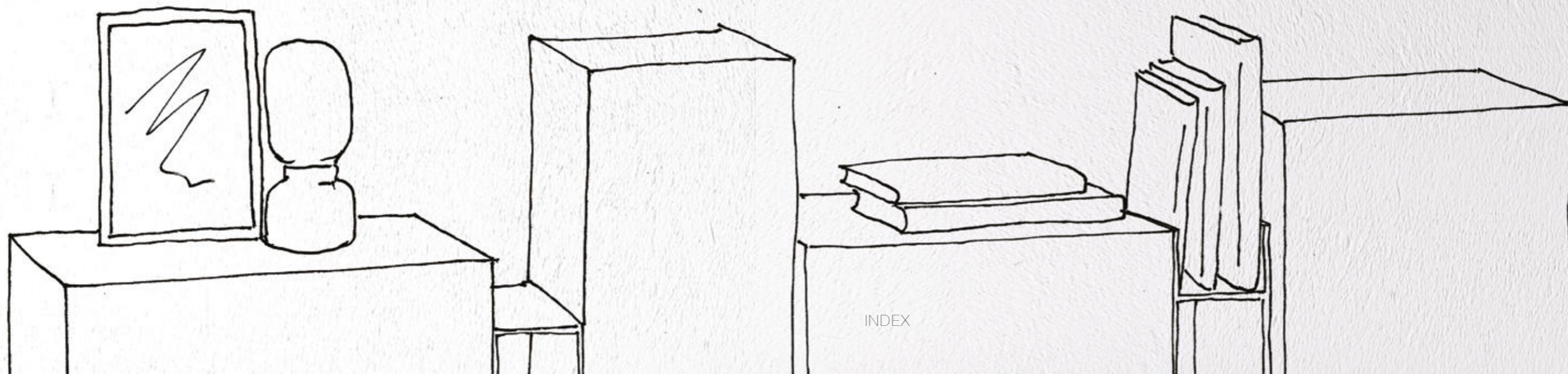

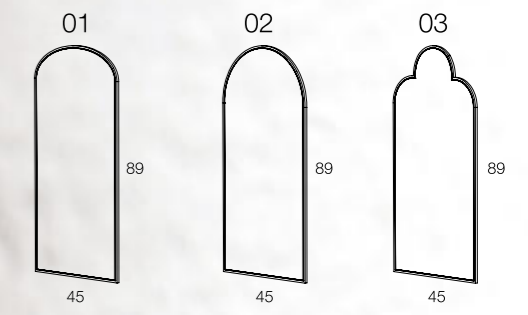

WI
NDO
WS

RI FLE ES SO D'ON DA

CLAUDIO LOVADINA



INDEX

RI
FL
ES
SO
D'ON
DA



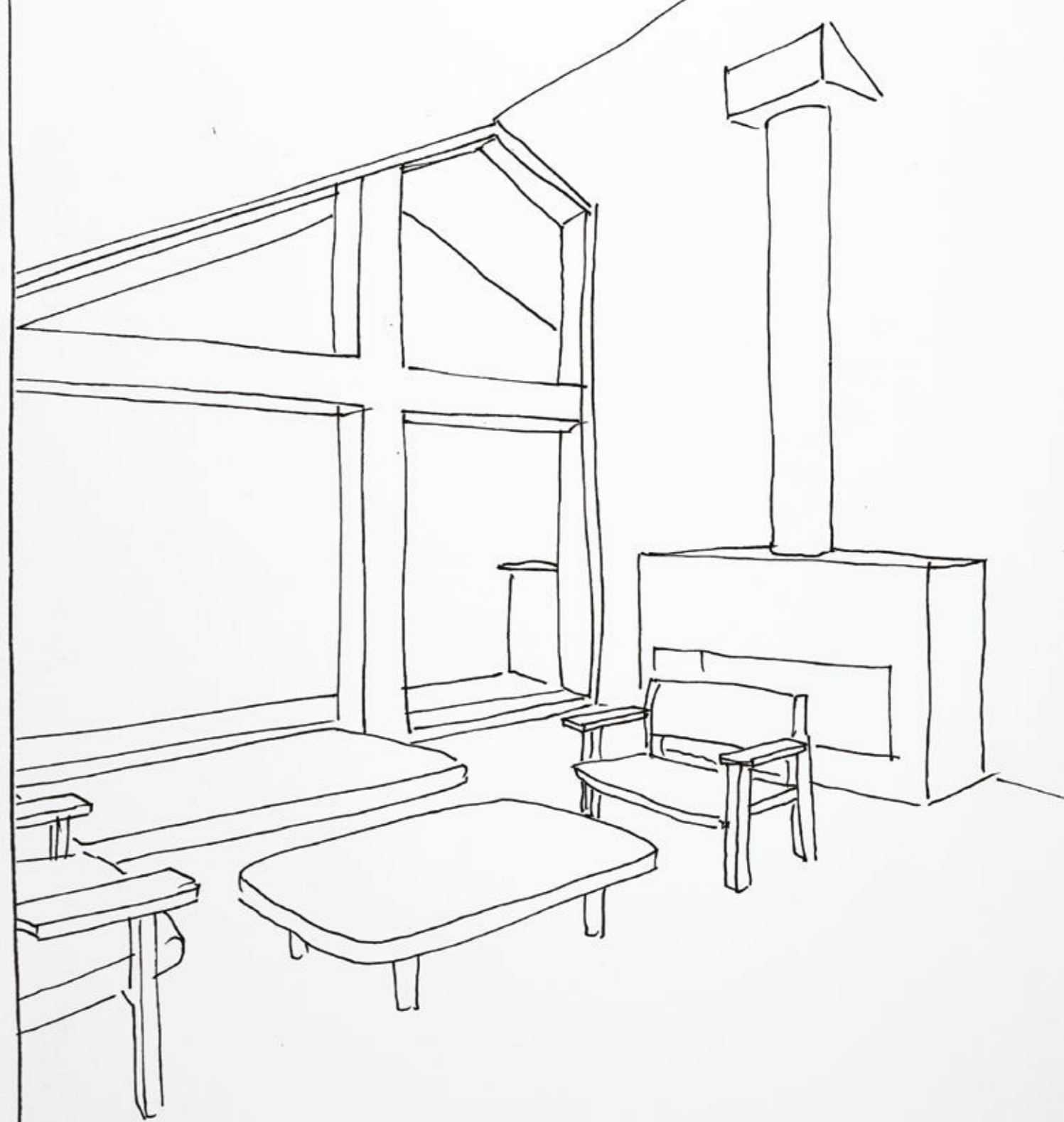

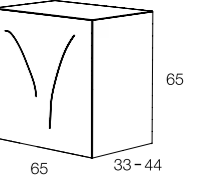

RI
FL
ES
SO
D'ON
DA





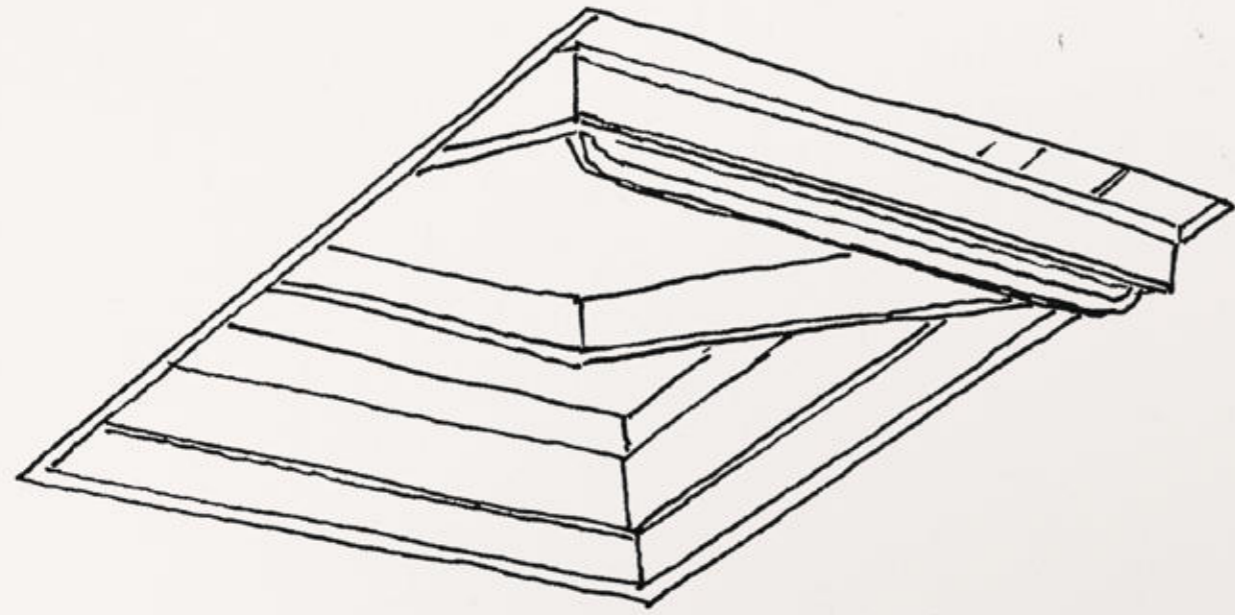

CAN
TO



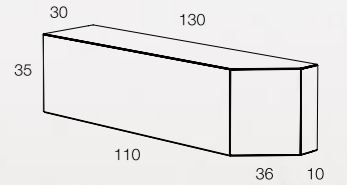

CANTONERA



THE GARDEN CITY
a study in SCARLET
FINANCIAL ACCOUNTING
THE OPEN HAND
I Didn't WRITE THIS BOOK
In Search Of Fatherhood
WALDEN
ARTHUR CONAN DOYLE
JEFF WATTS
KEVIN RENNER

THE OPEN HAND
LE CORBUSIER
WALDEN

THE OPEN HAND
LE CORBUSIER
WALDEN

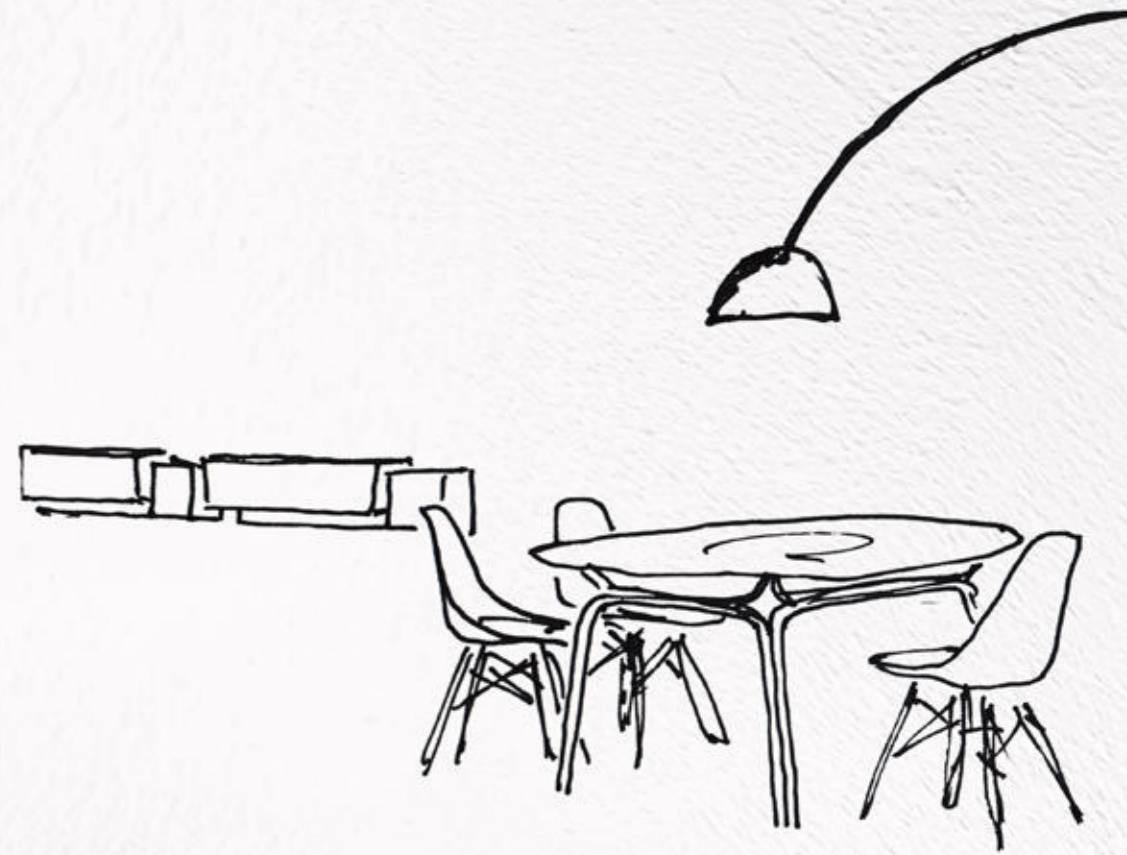
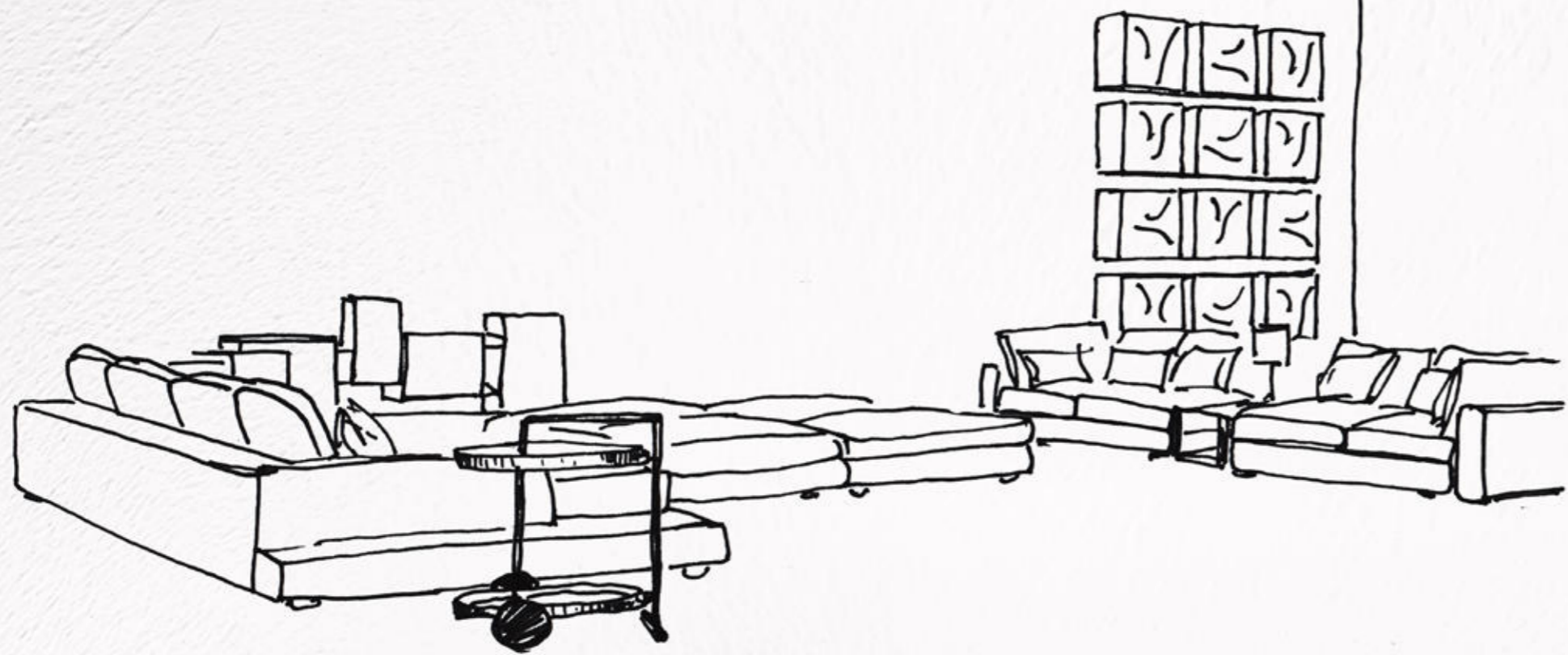
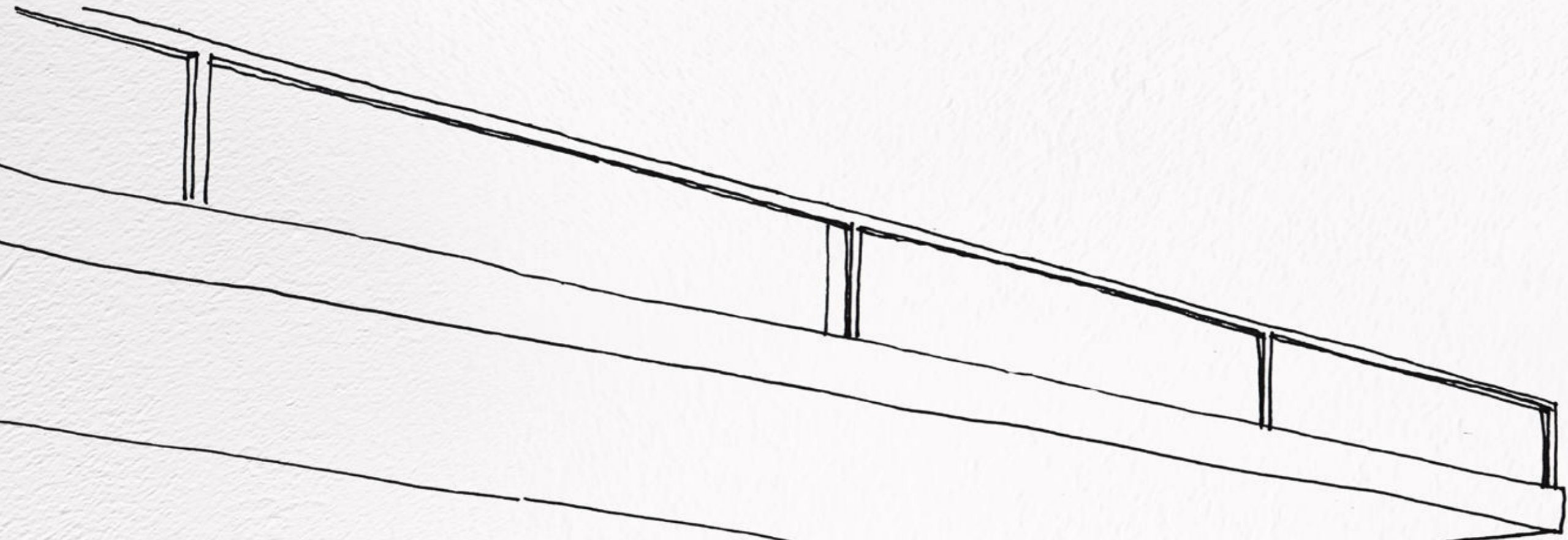

DO RO TEA

CLAUDIO LOVADINA

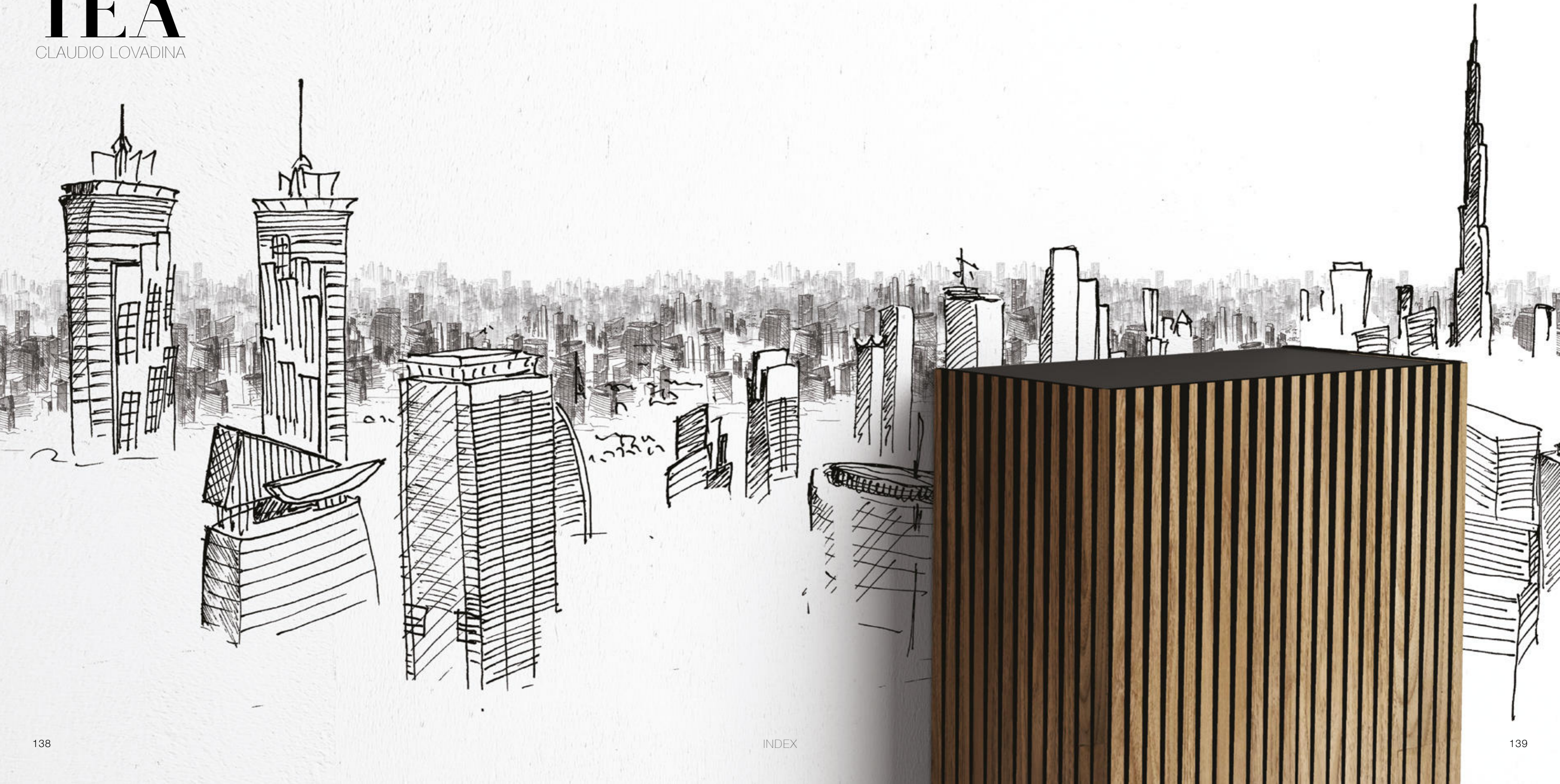

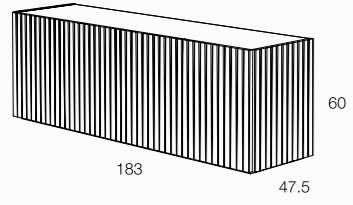

DO
RO
TEA



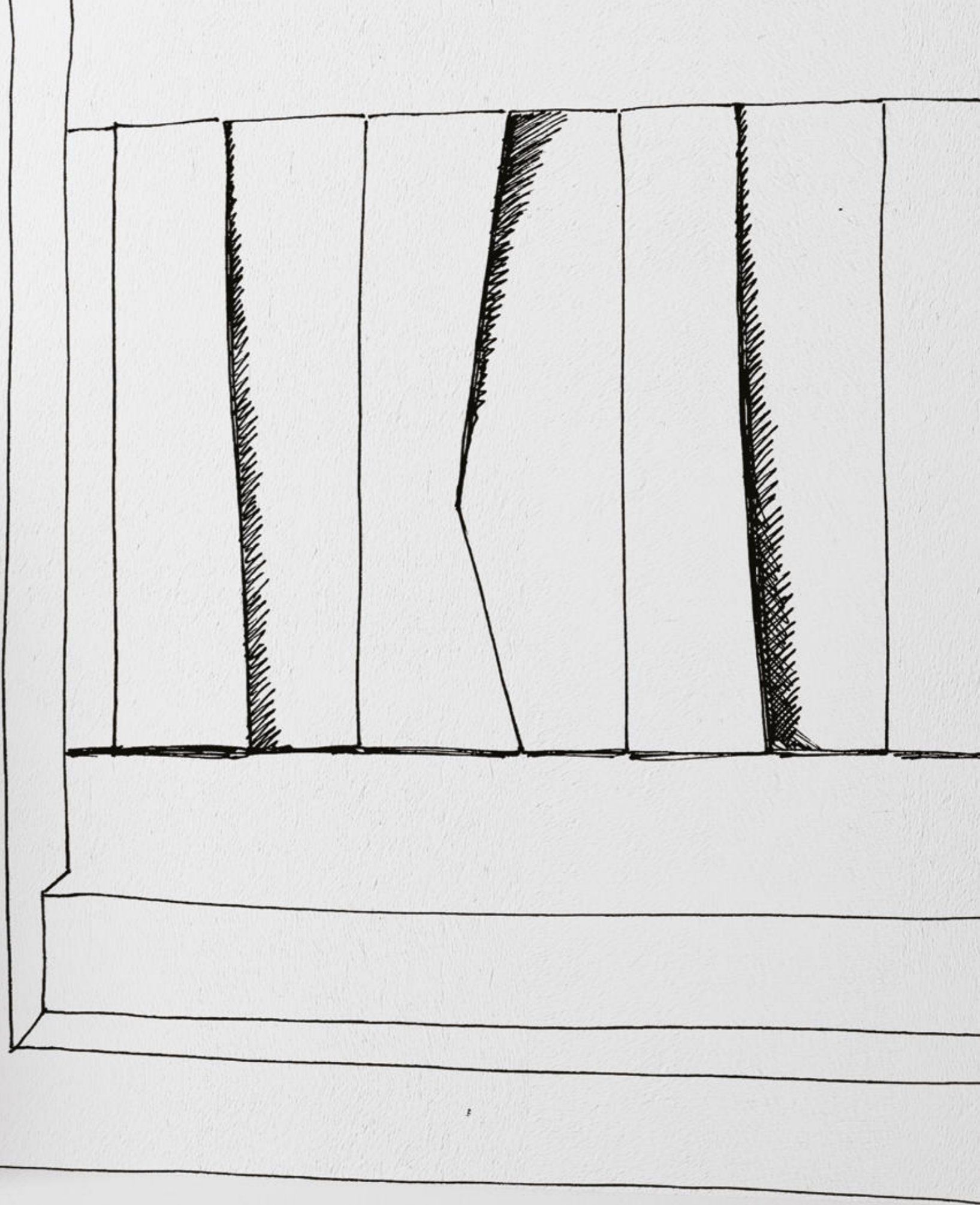

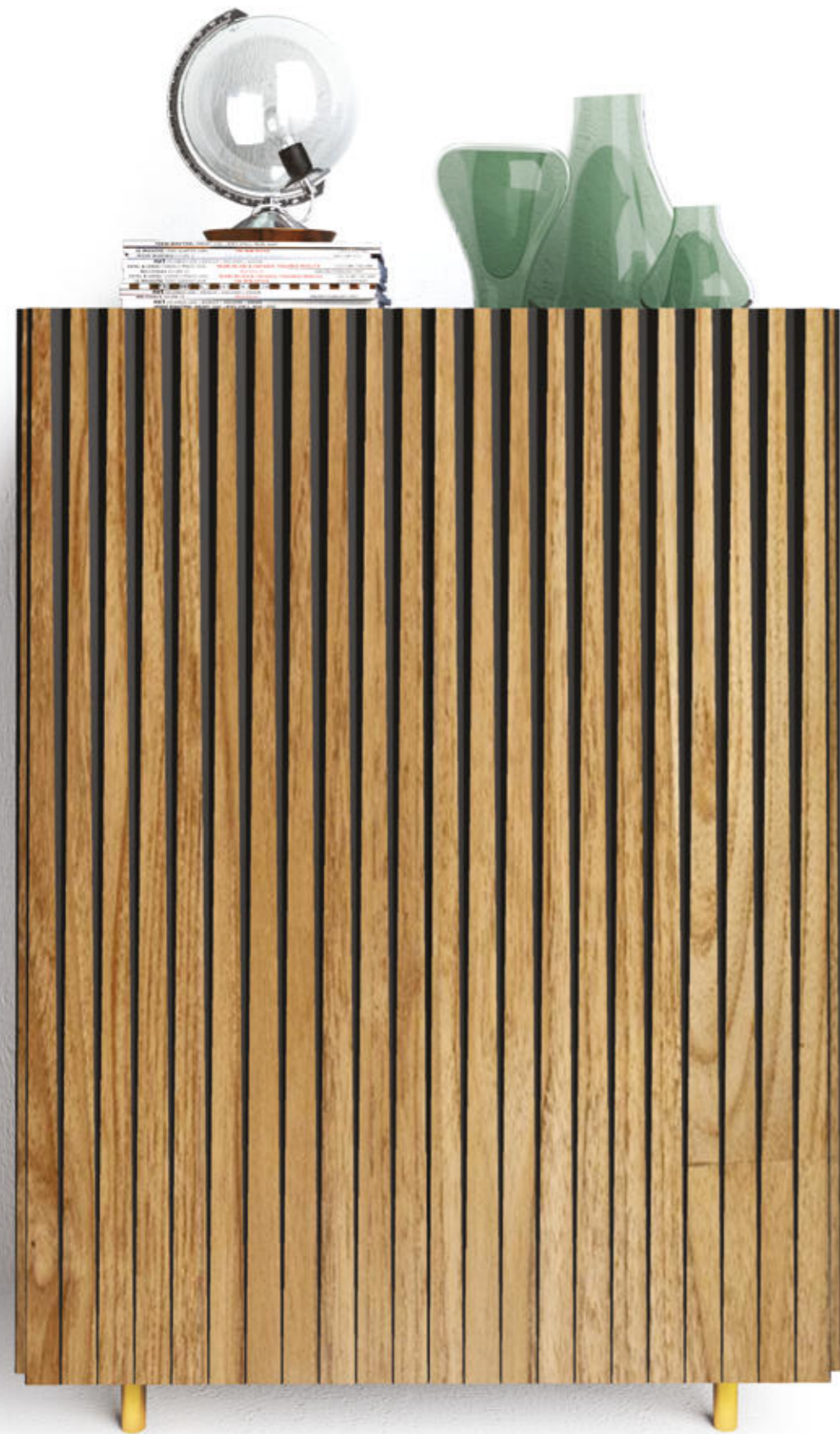
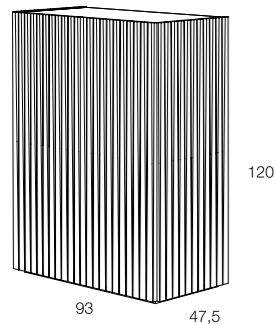

DO
RO
TEA



SAMURAI

SIMONE
FANCIULLACCI



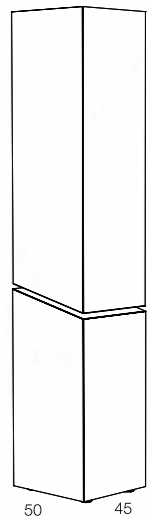

215

50

45



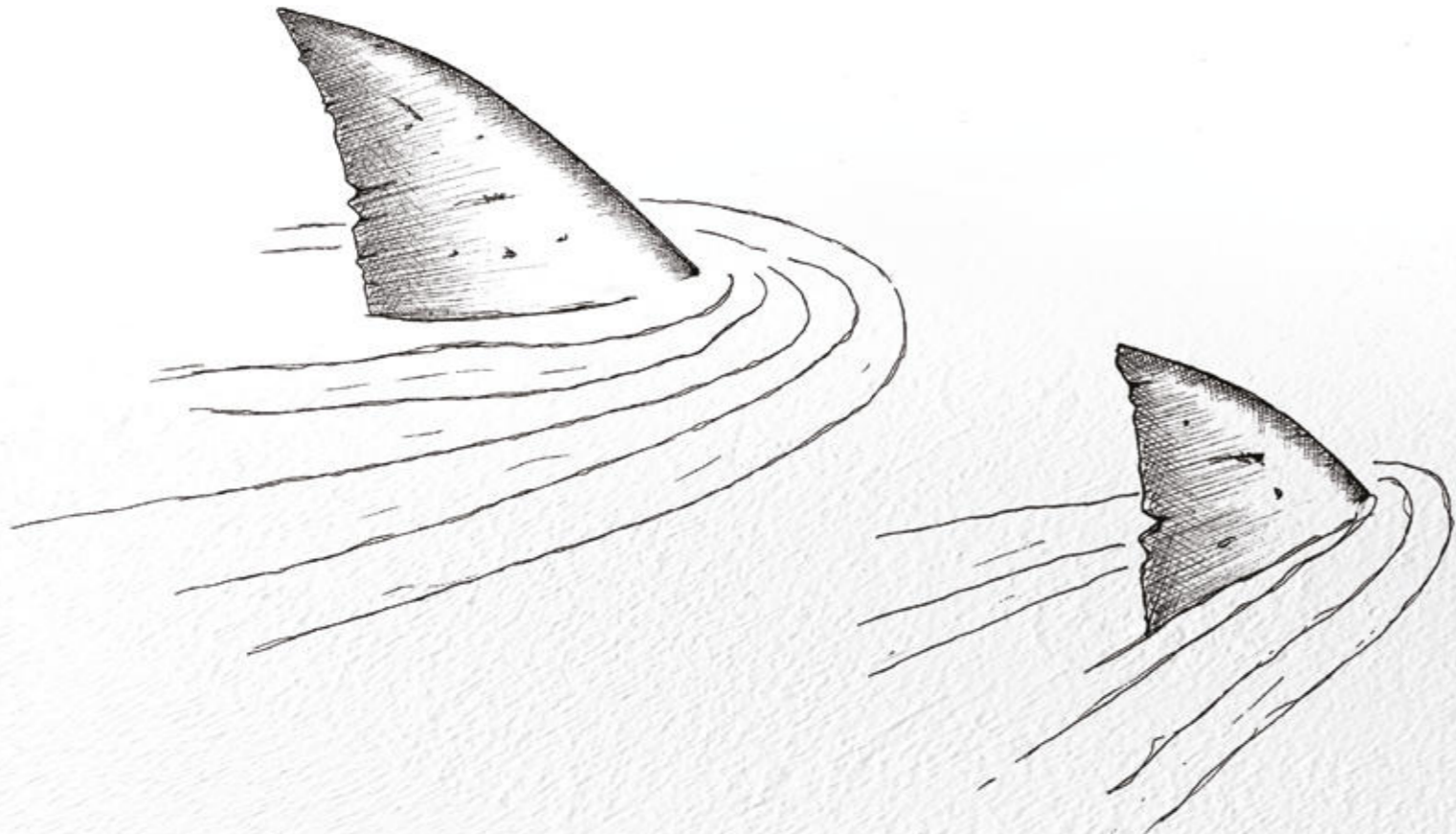

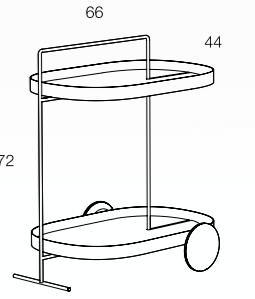

AT
OL
LO

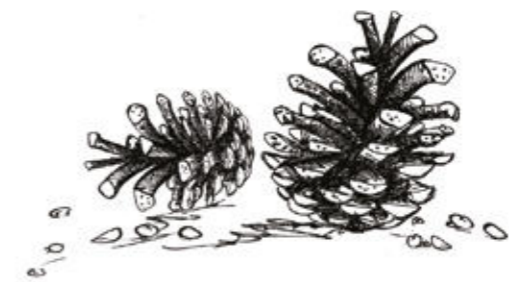

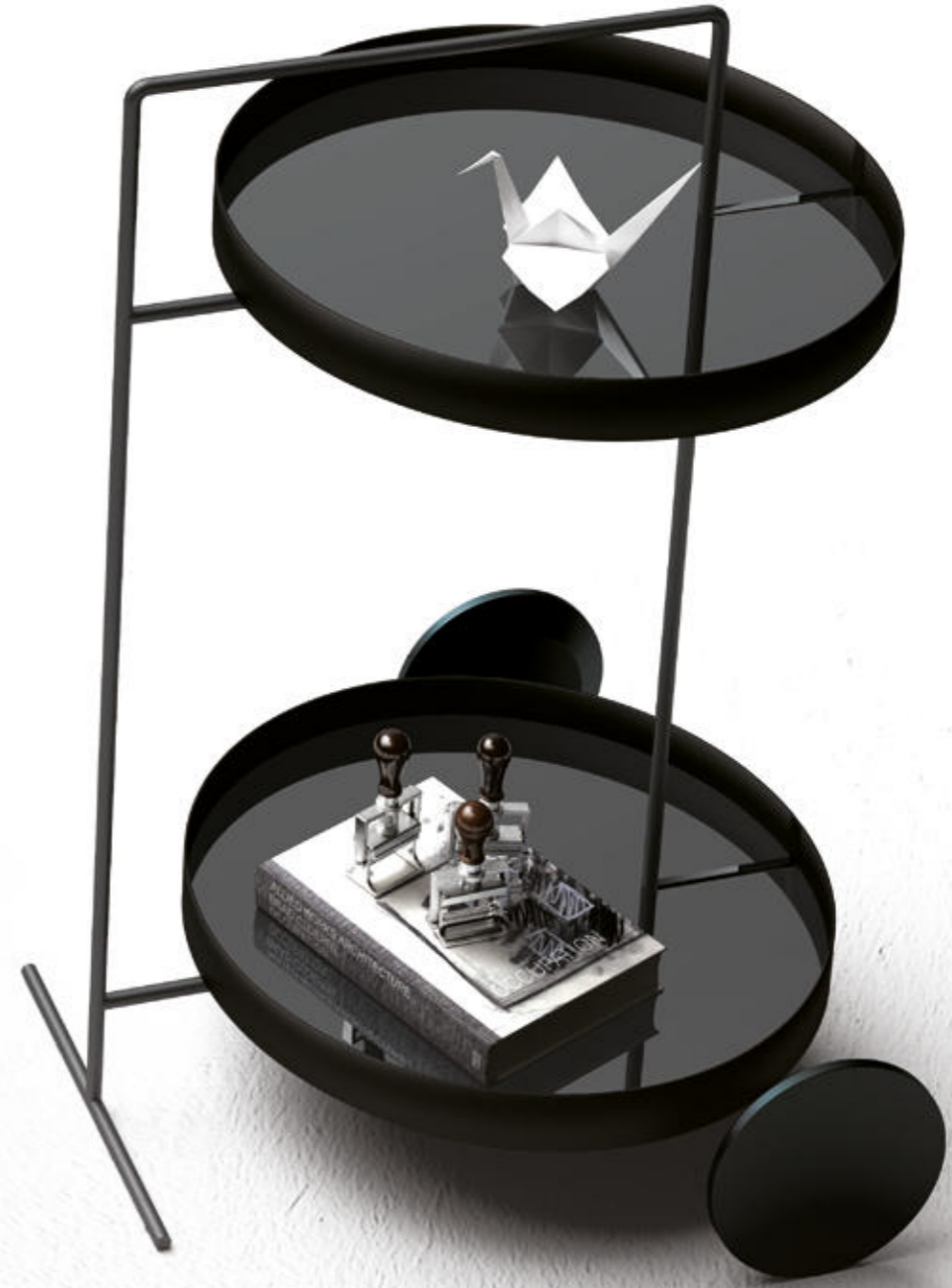
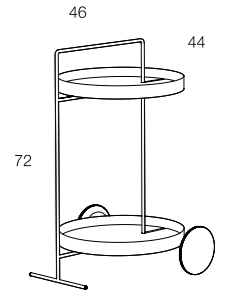
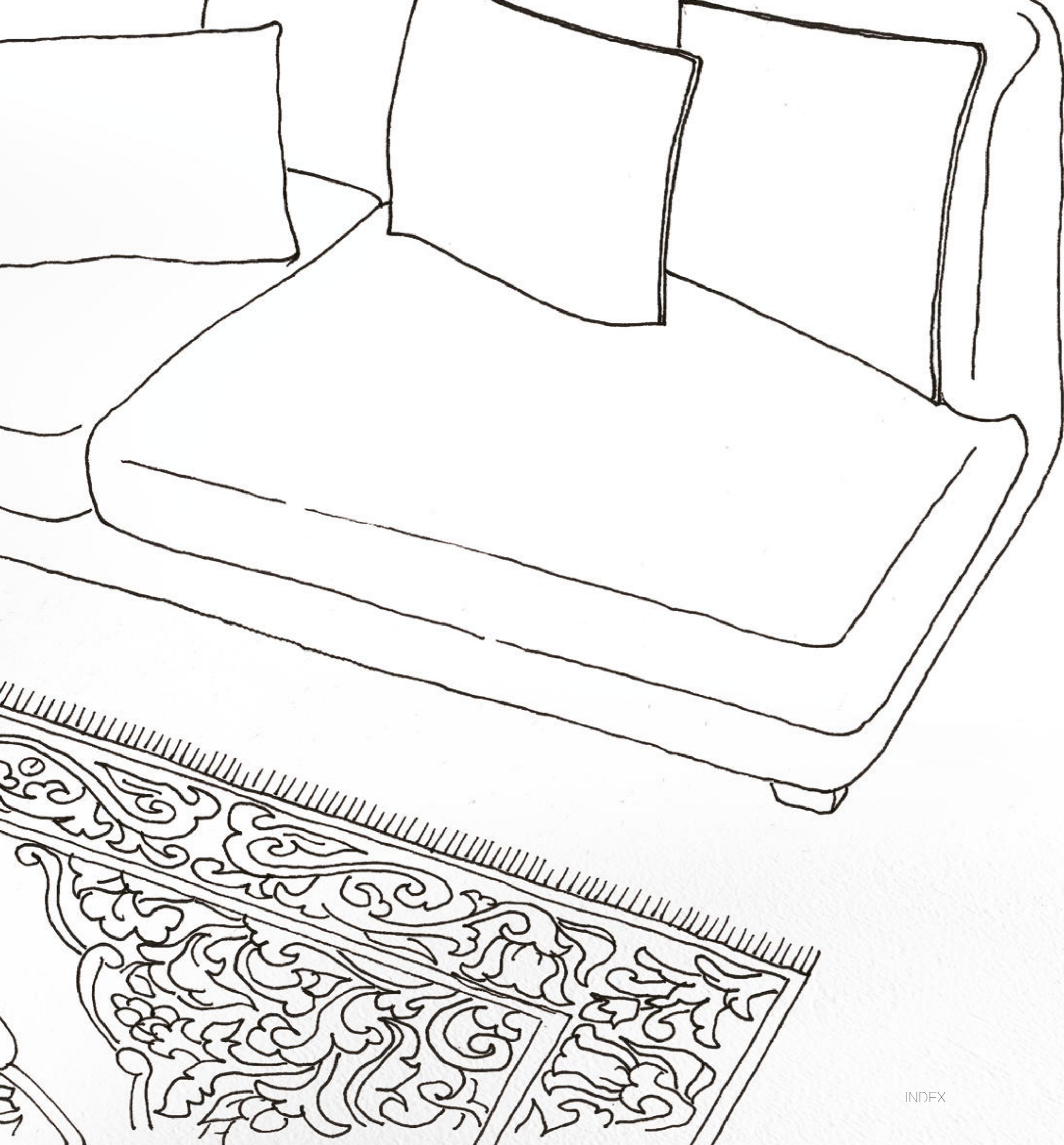

AT
OL
LO



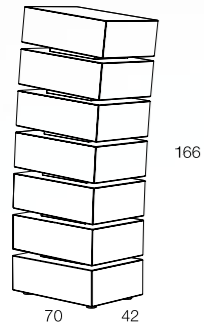

PI SA

CNY



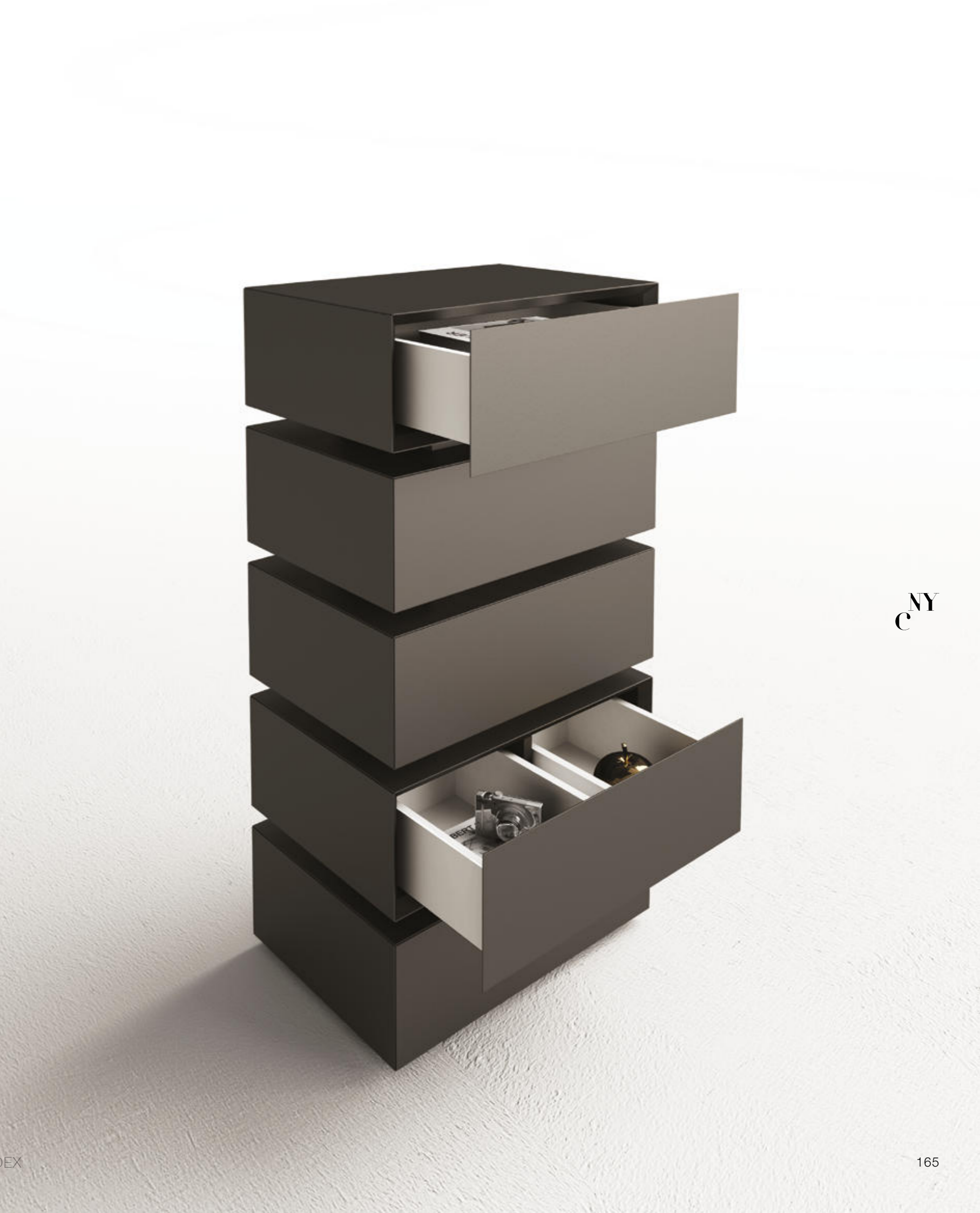

CLEOPATRA

DSH



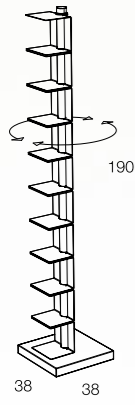

CLEOPATRA



60 BOOKS

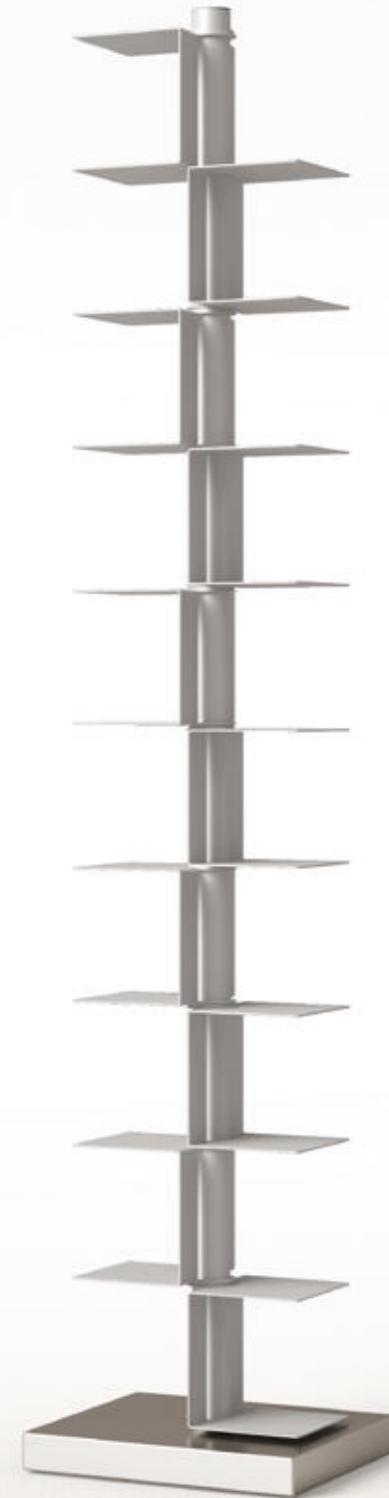

120 BOOKS



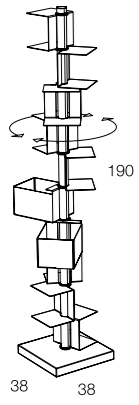

CLEOPATRA



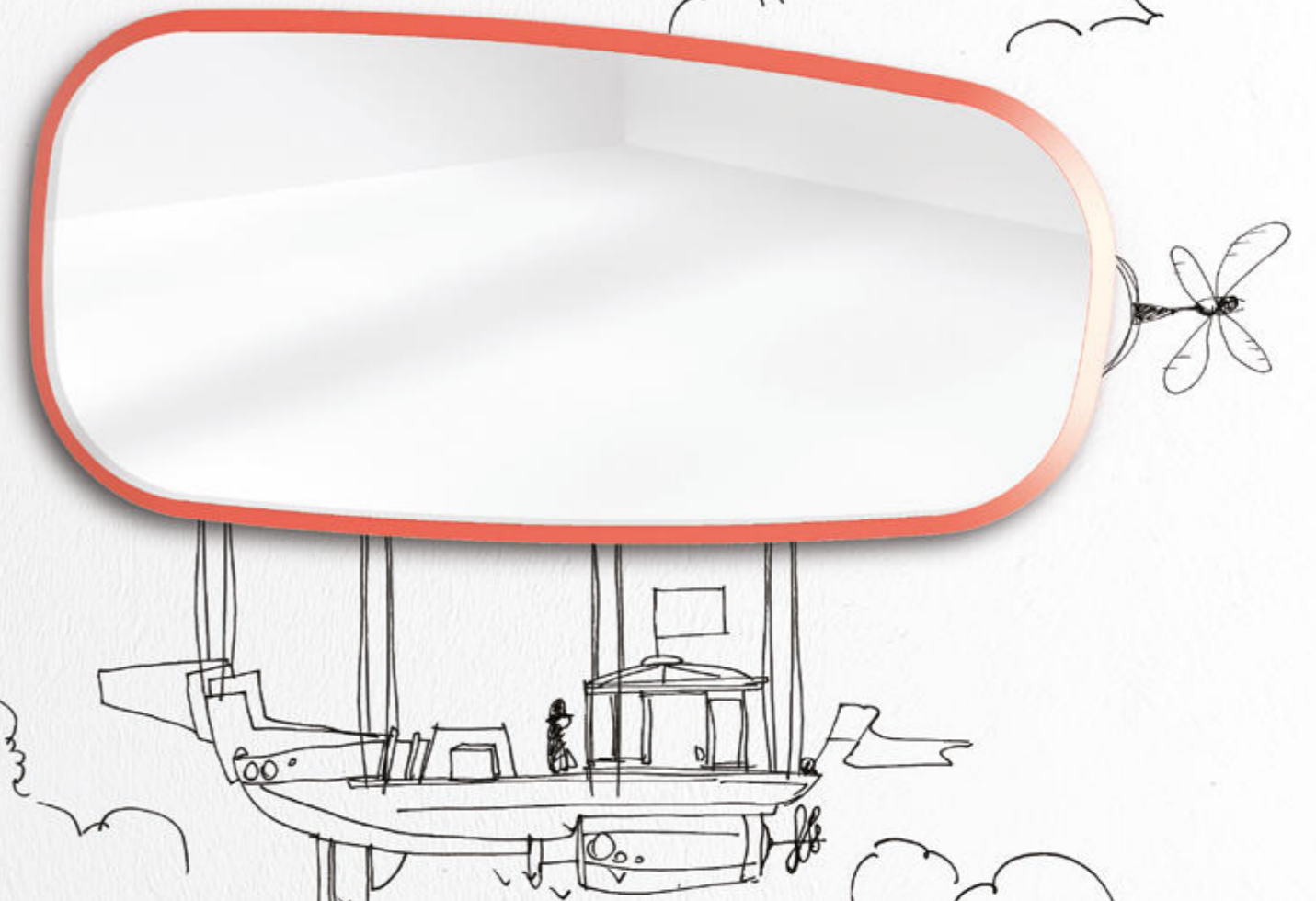
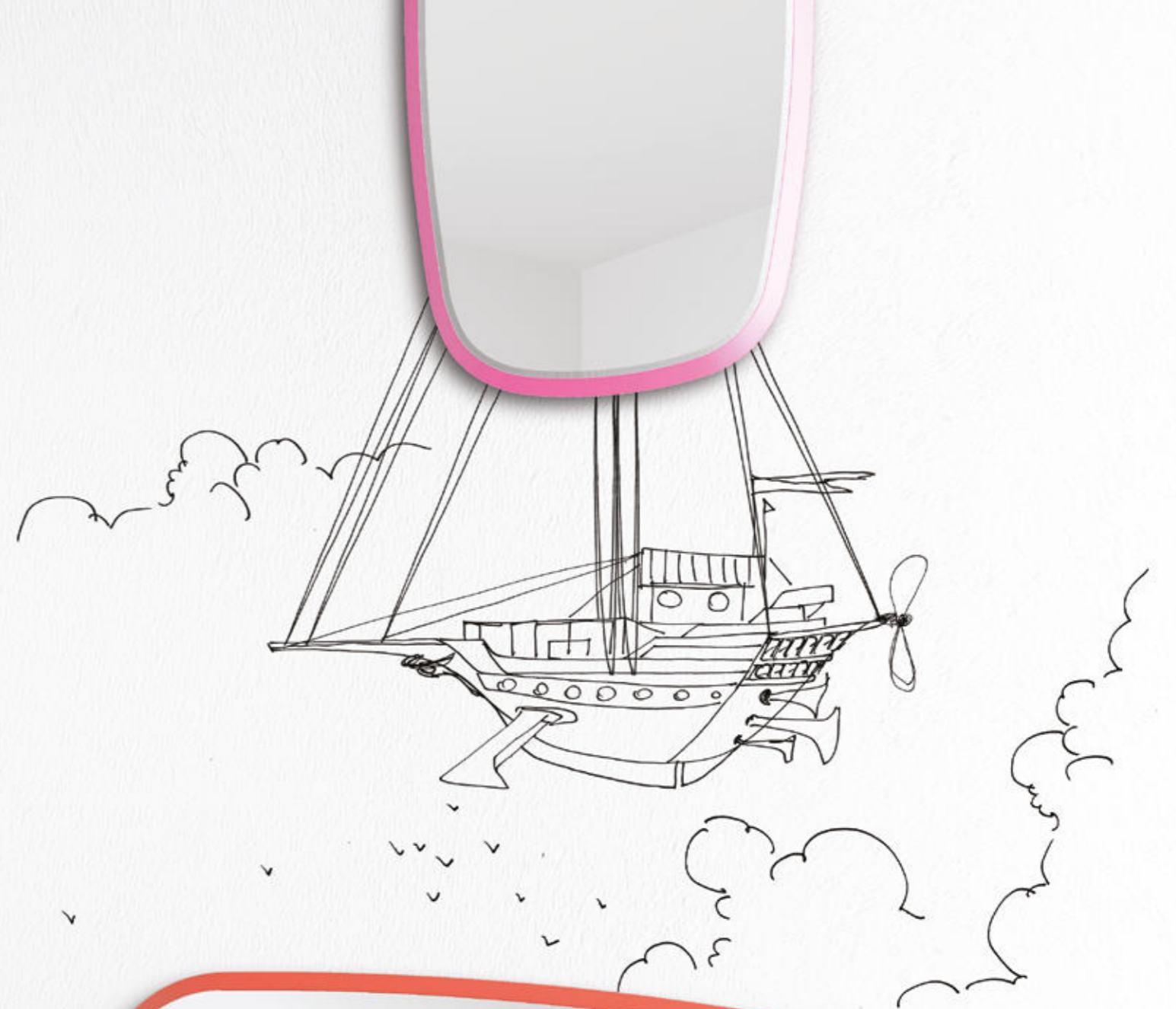
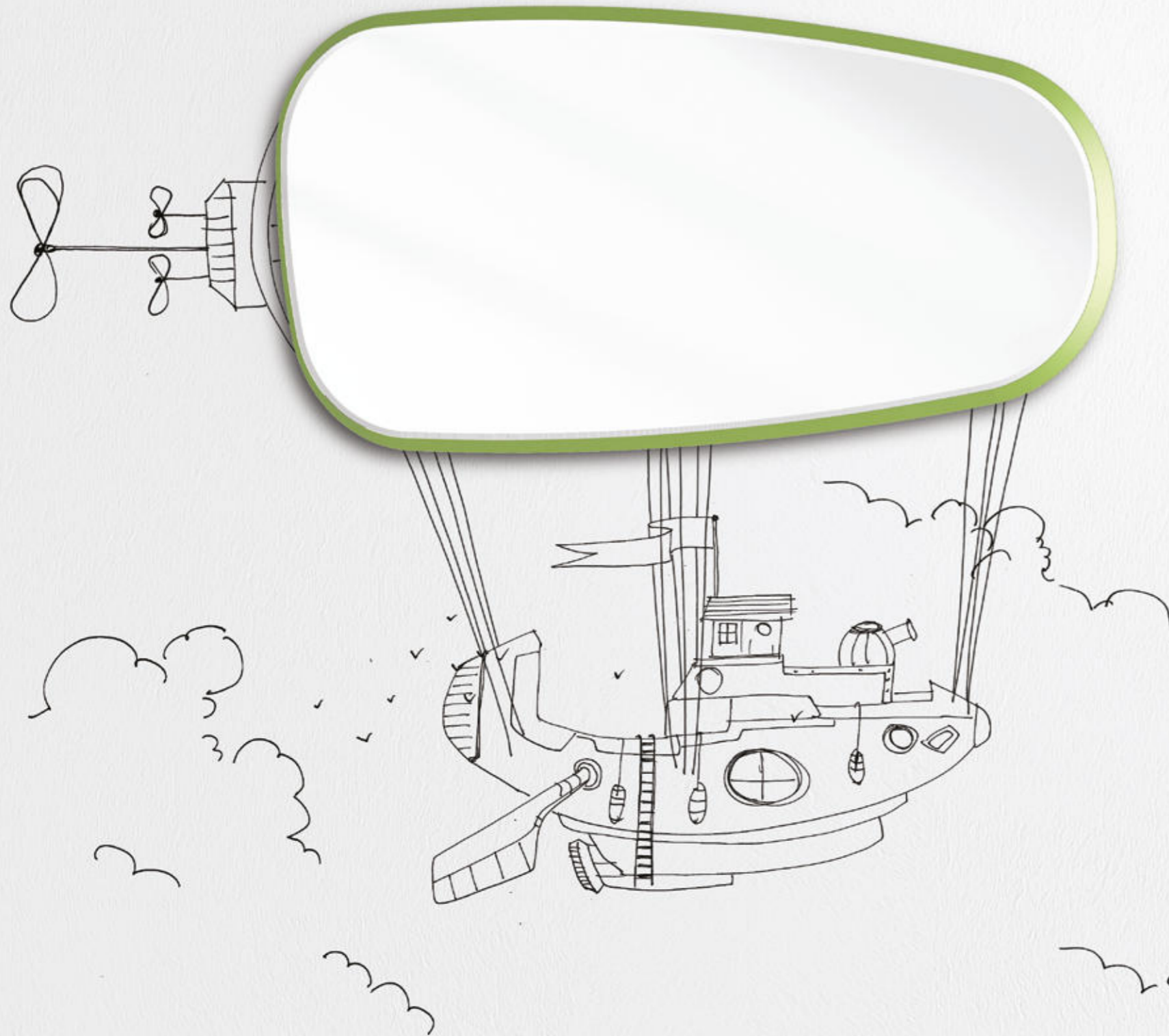

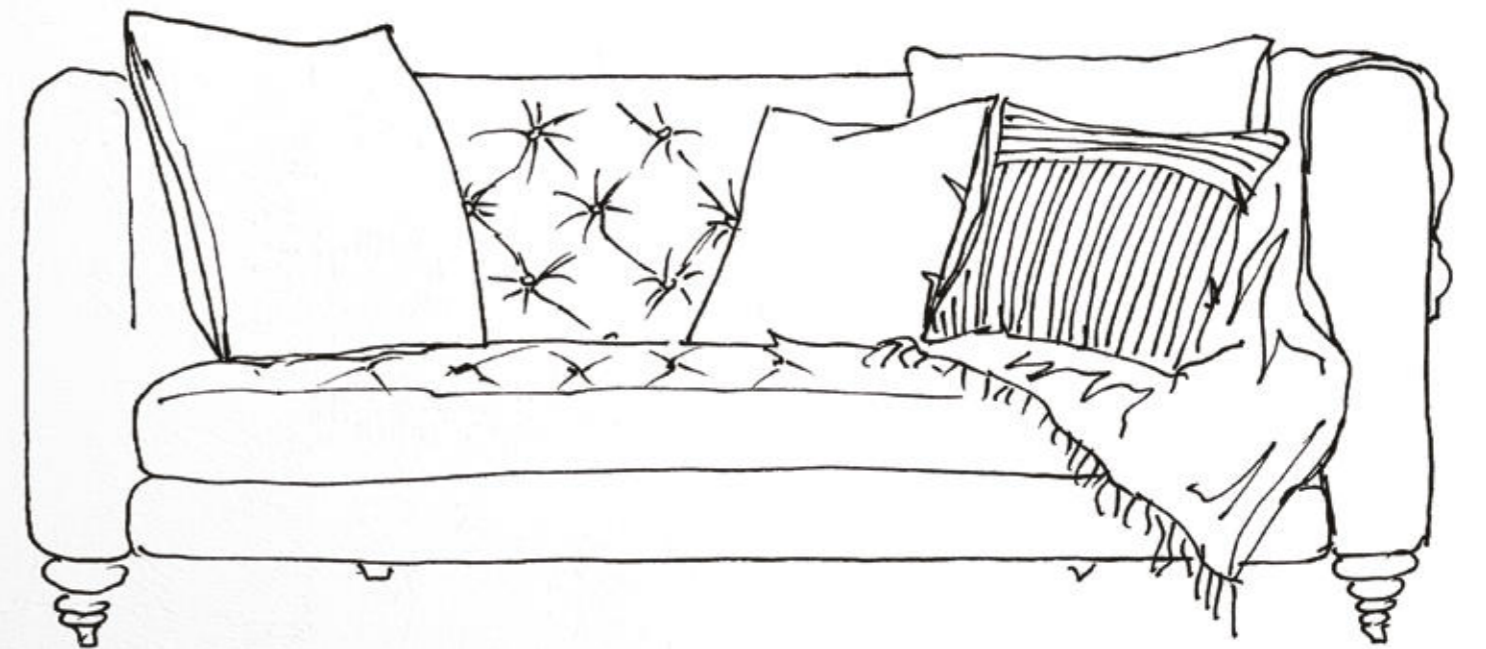
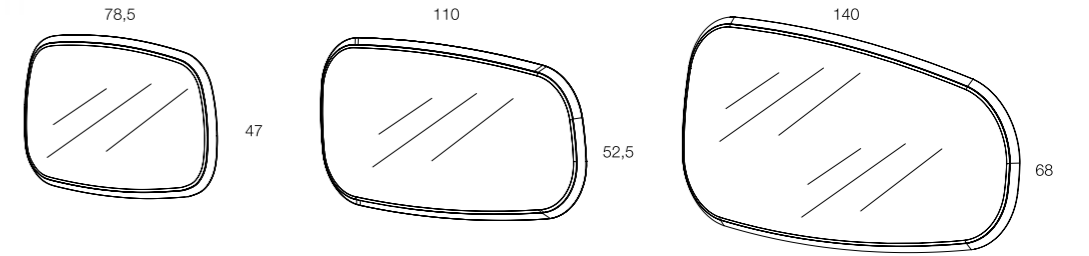
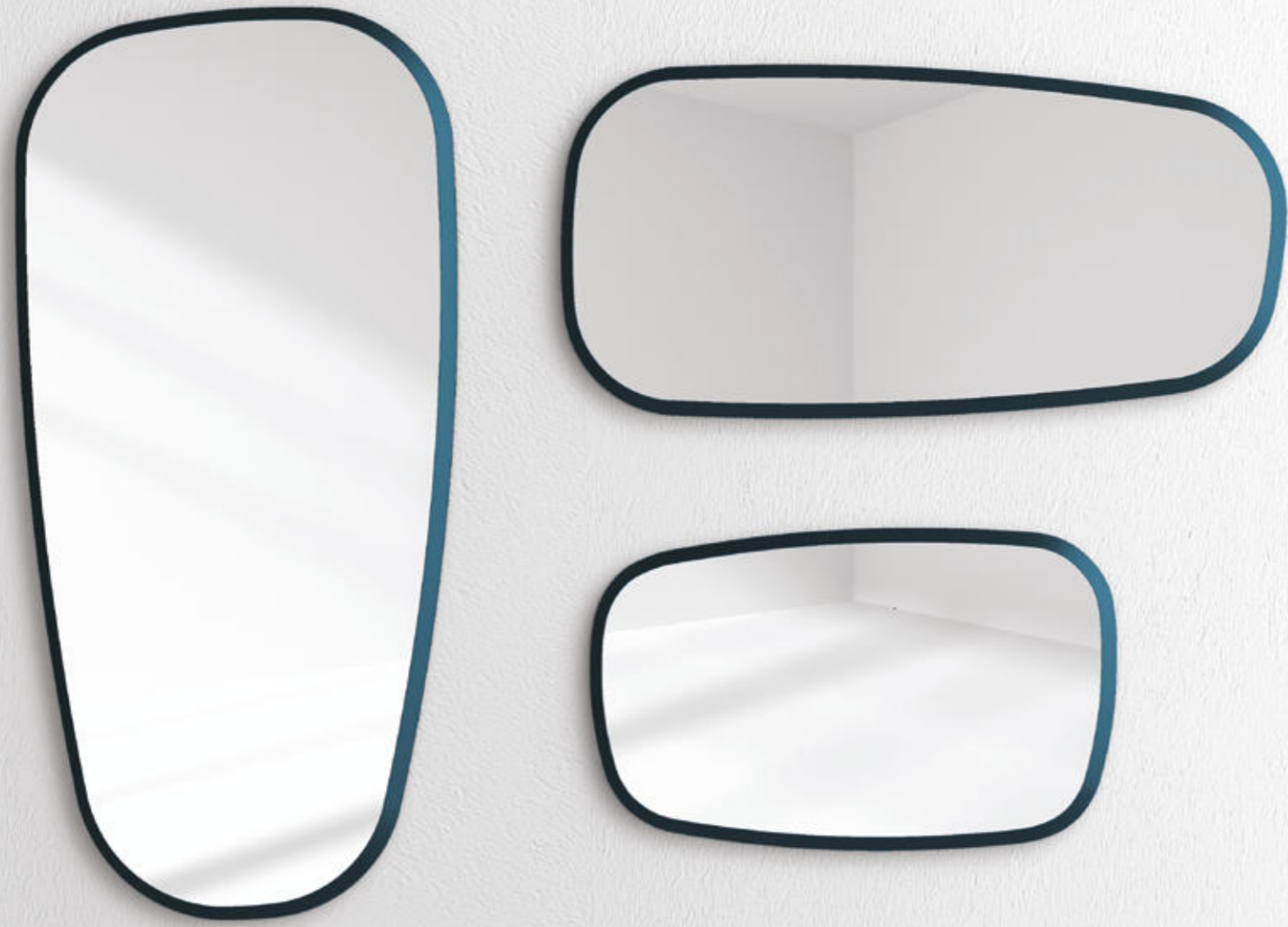

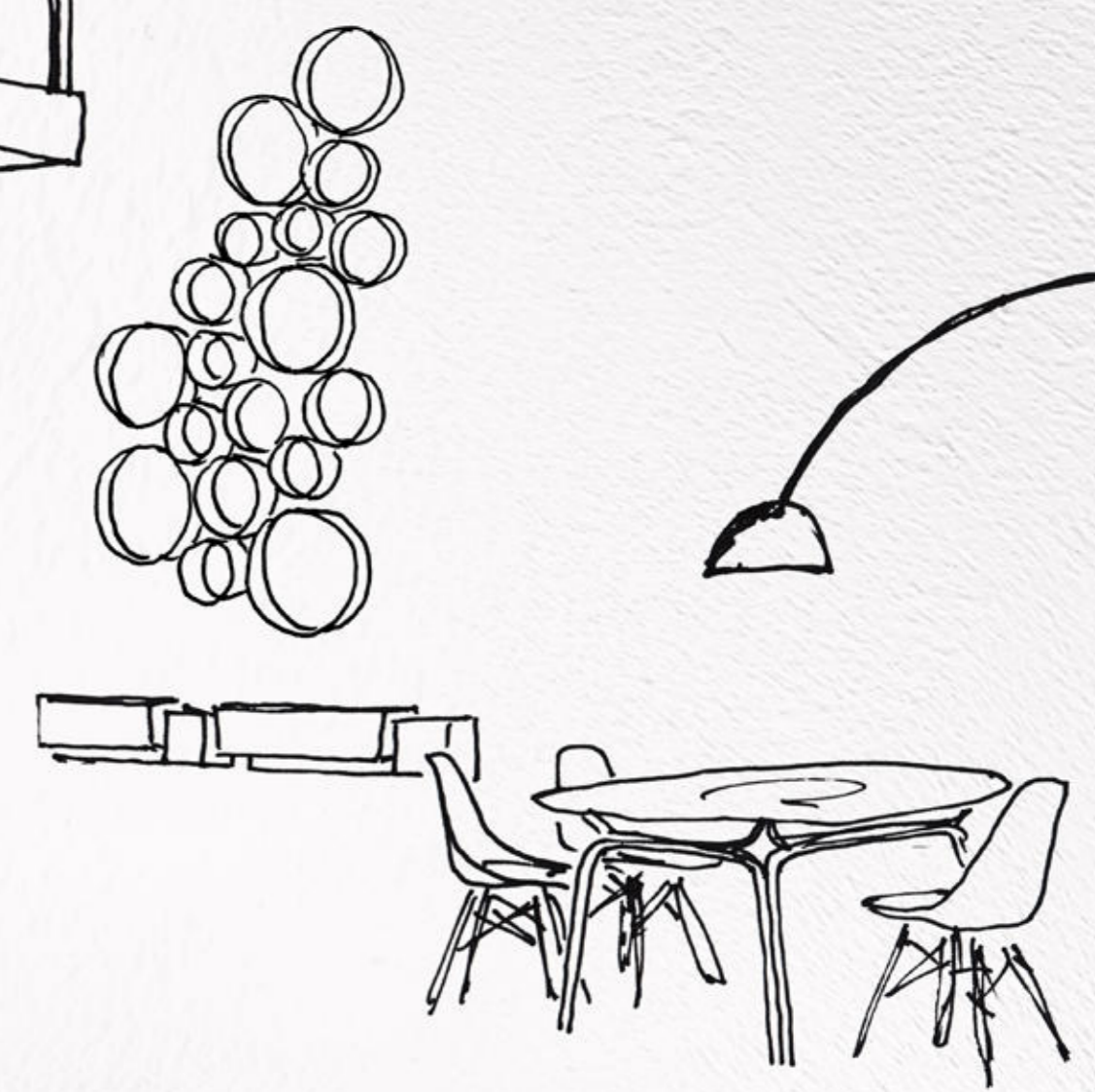

PO NTIA NA

FILIPPO MAMBRETTI

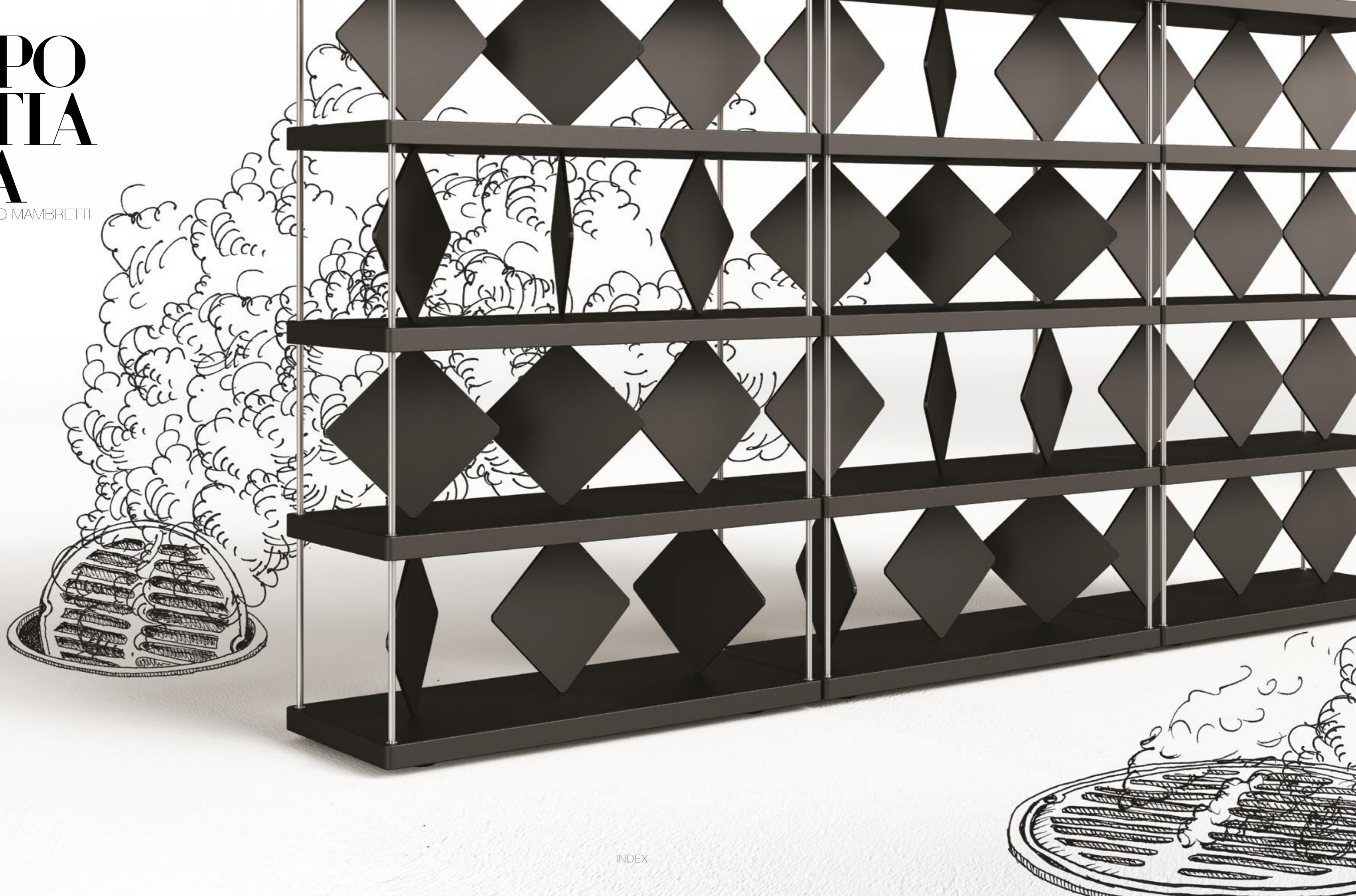



PO
NTIA
NA

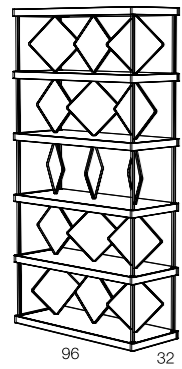

PO
NTIA
NA



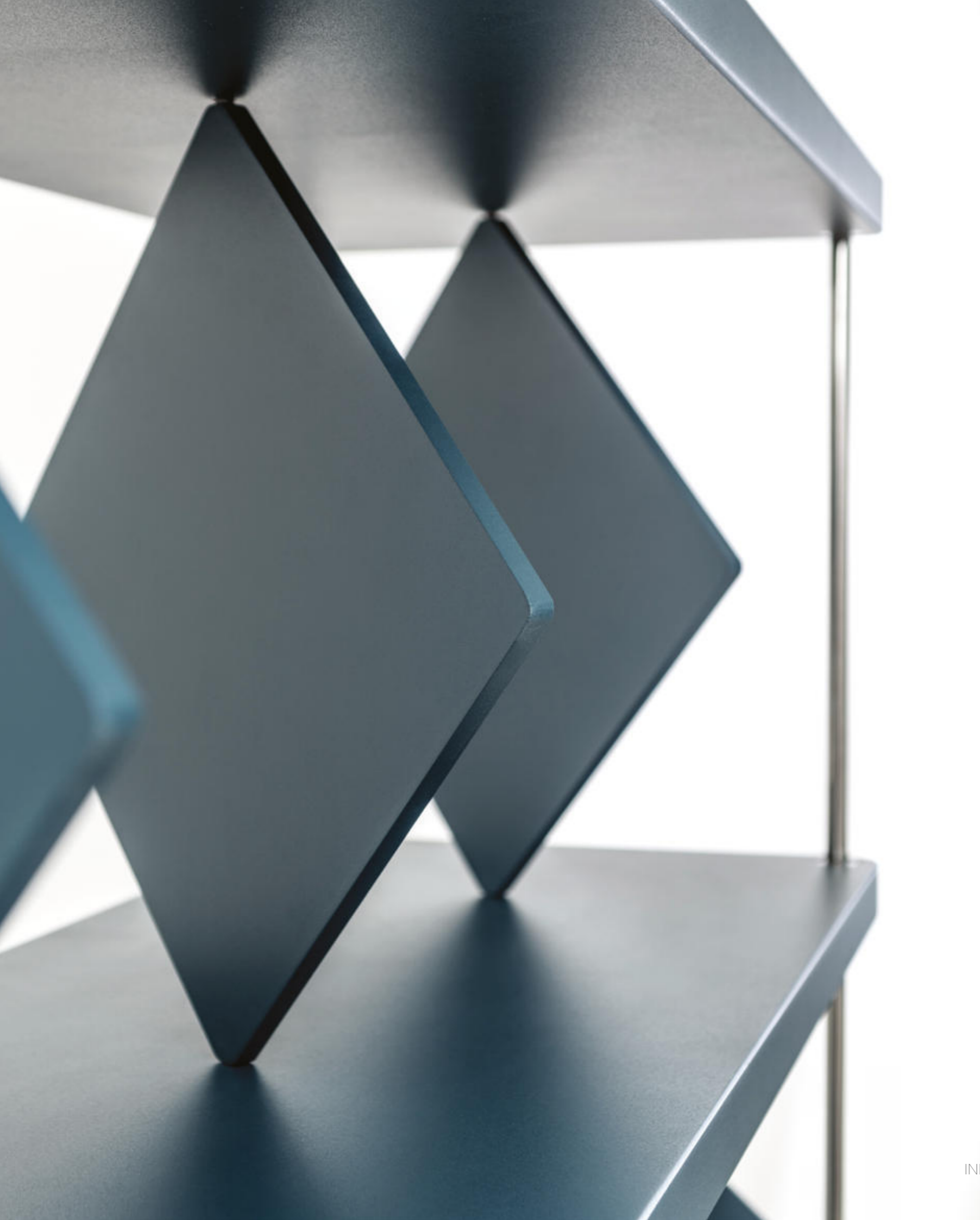



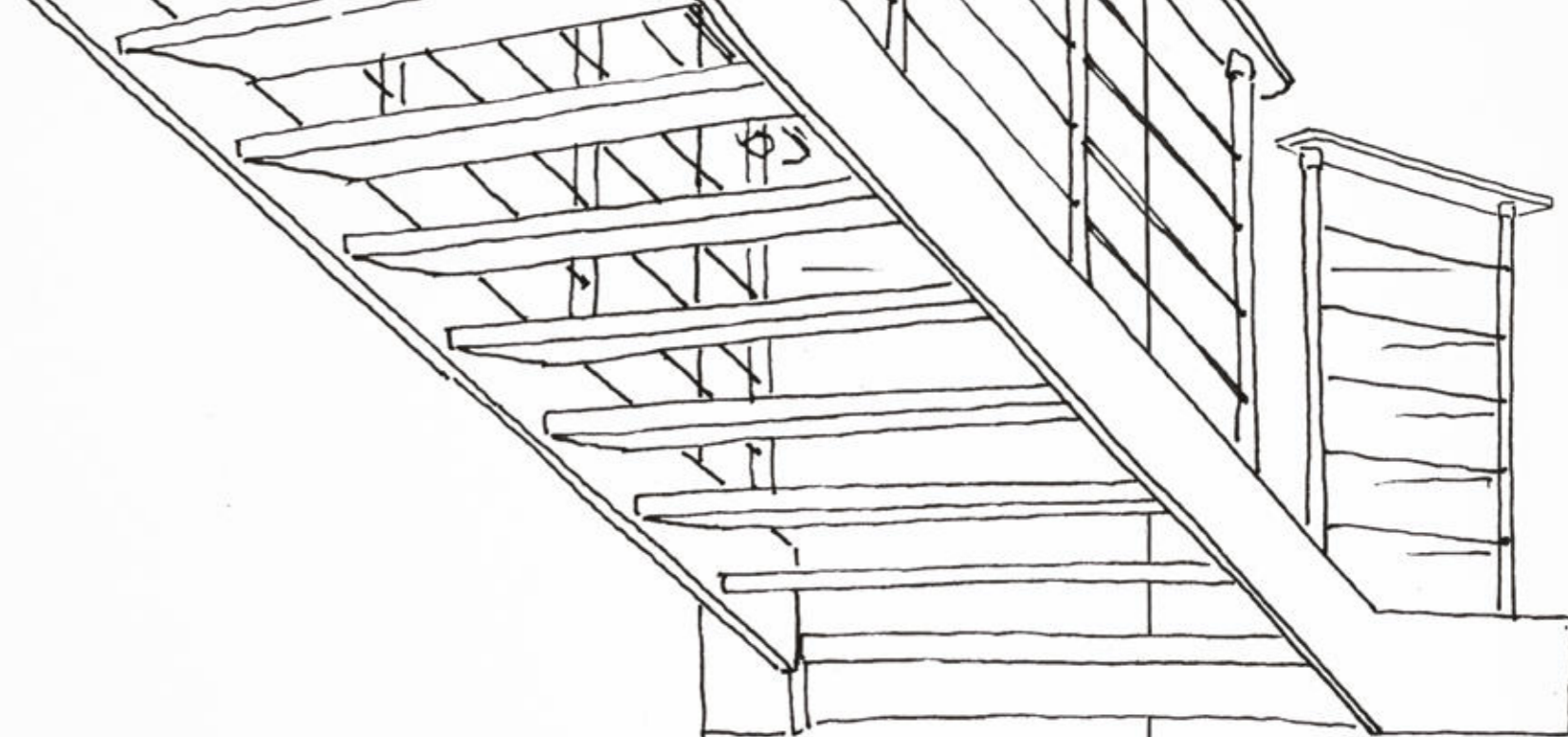

SHO
RE

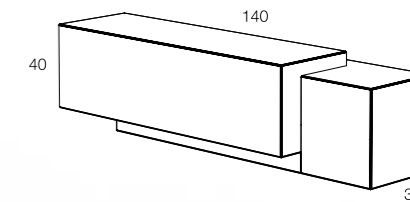

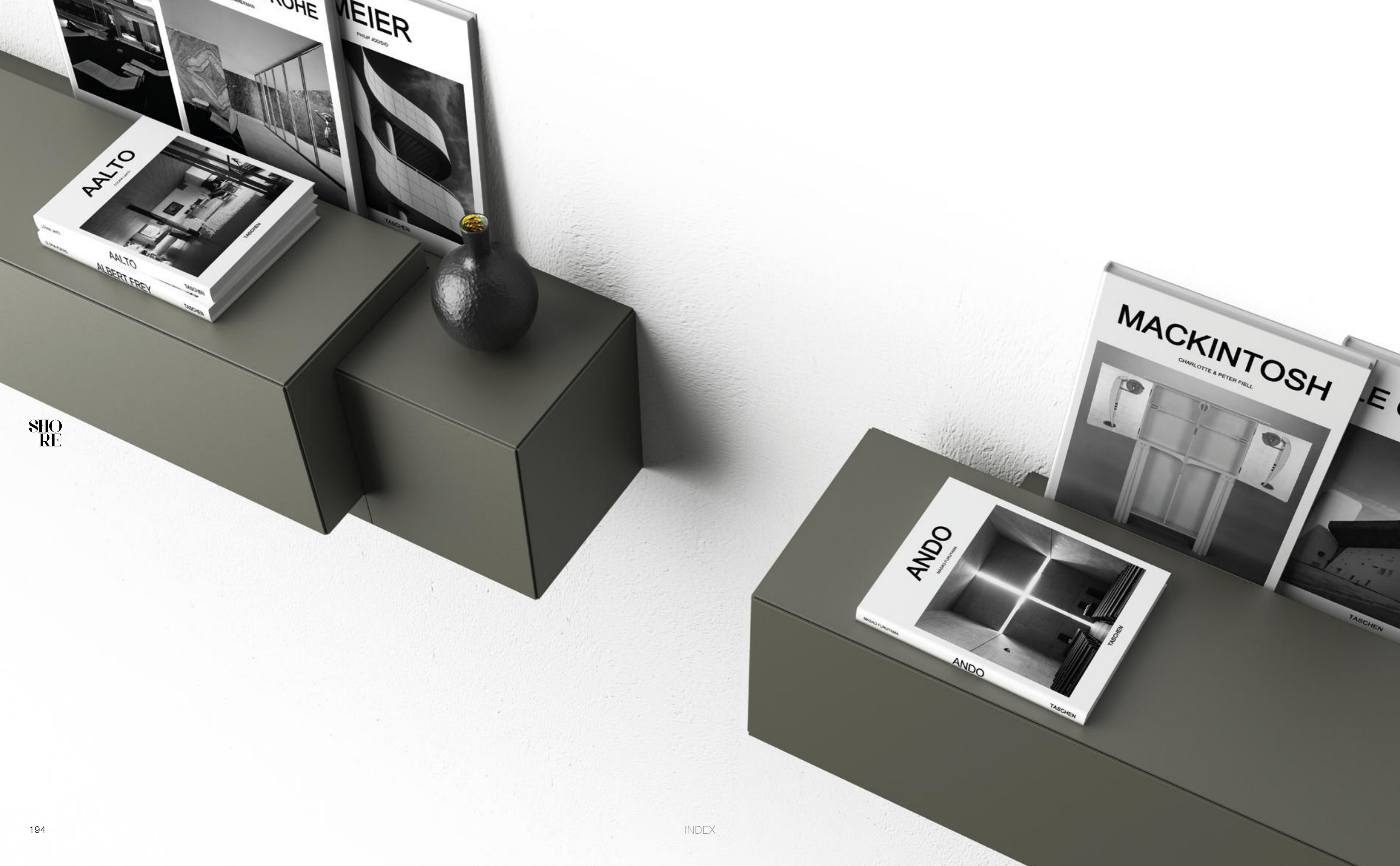

SHORE

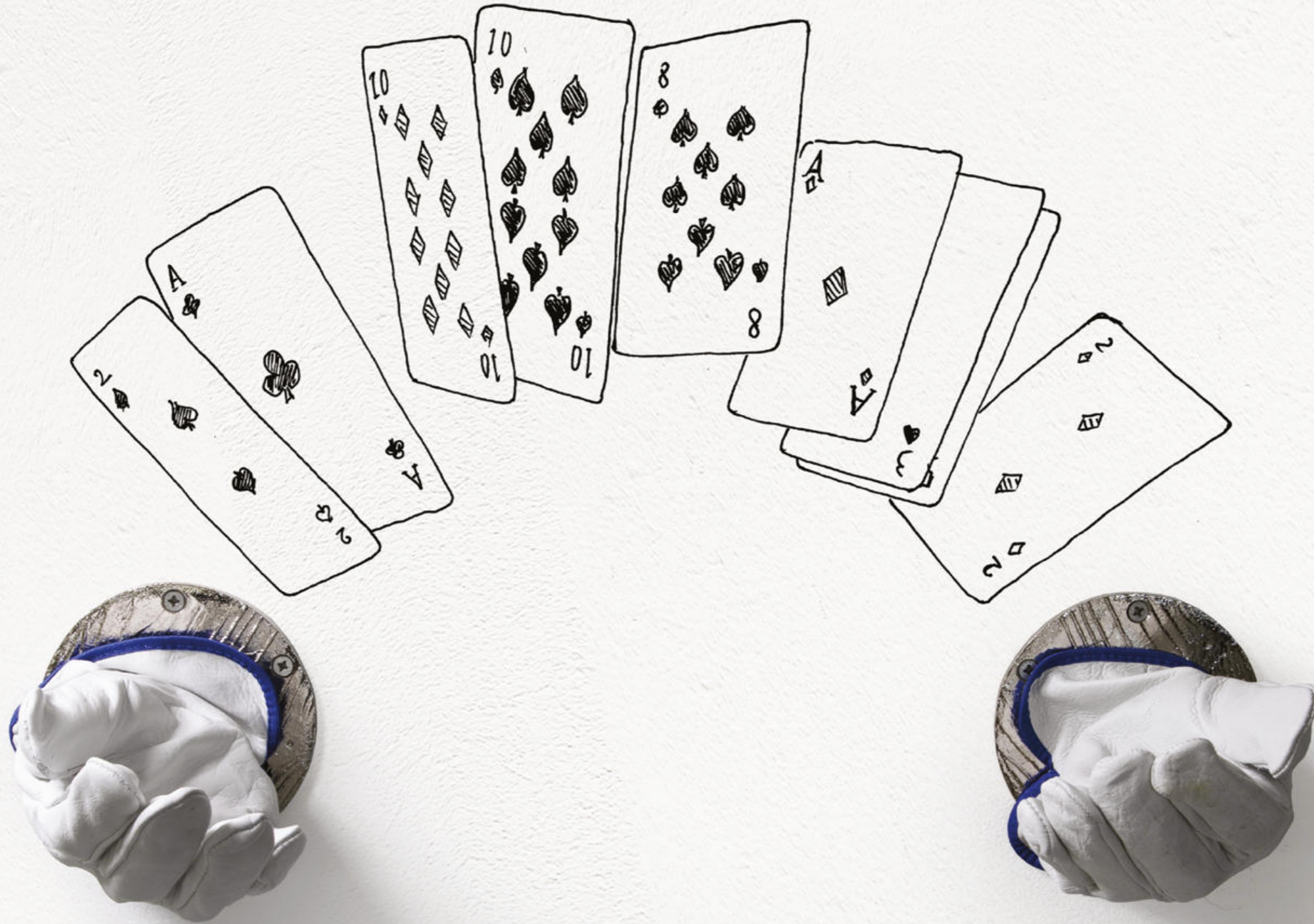



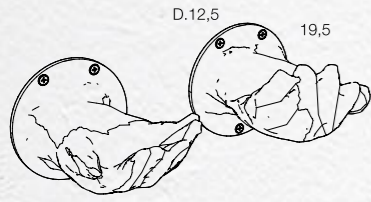

MI
MI'



TIM PA NO

CLAUDIO LOVADINA





TIM
PA
NO

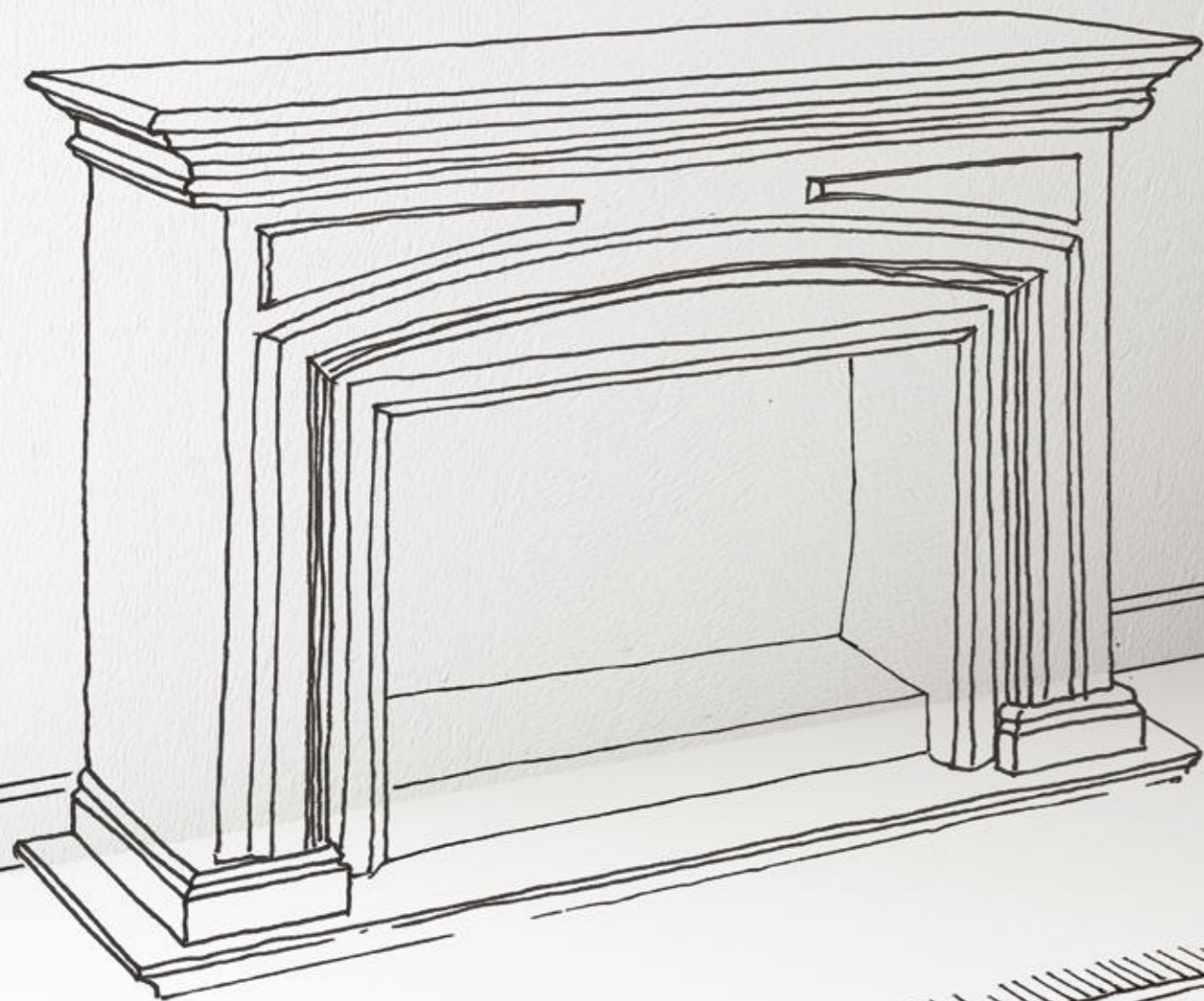

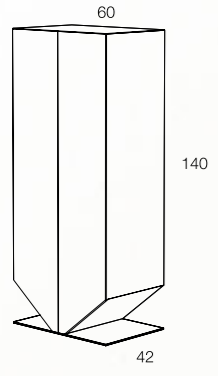

TIM
PA
NO



CH IO DO FI DO SS SS

DSH



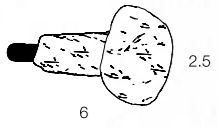

CH
DO
FI
SS

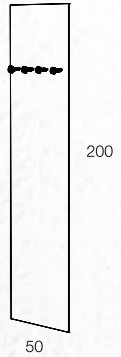
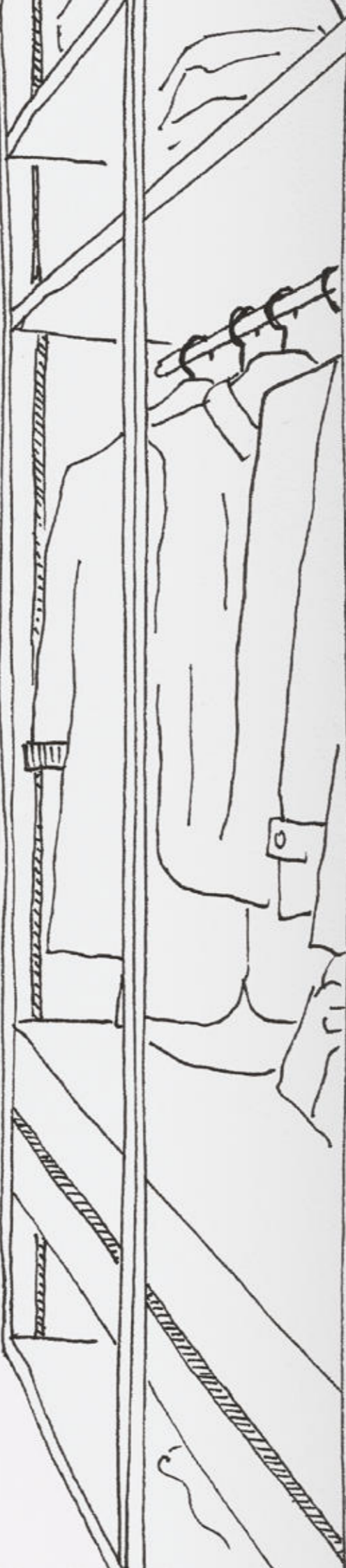
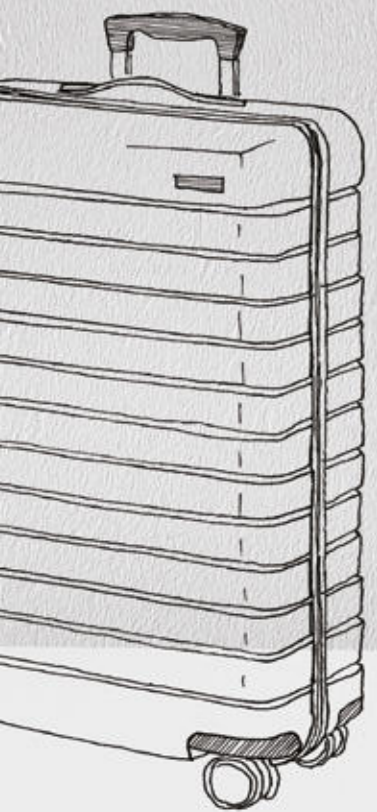
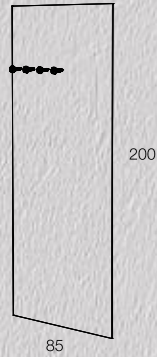

CH
DIO
S
S



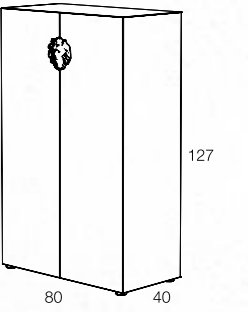
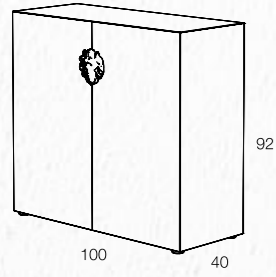

KL
NG

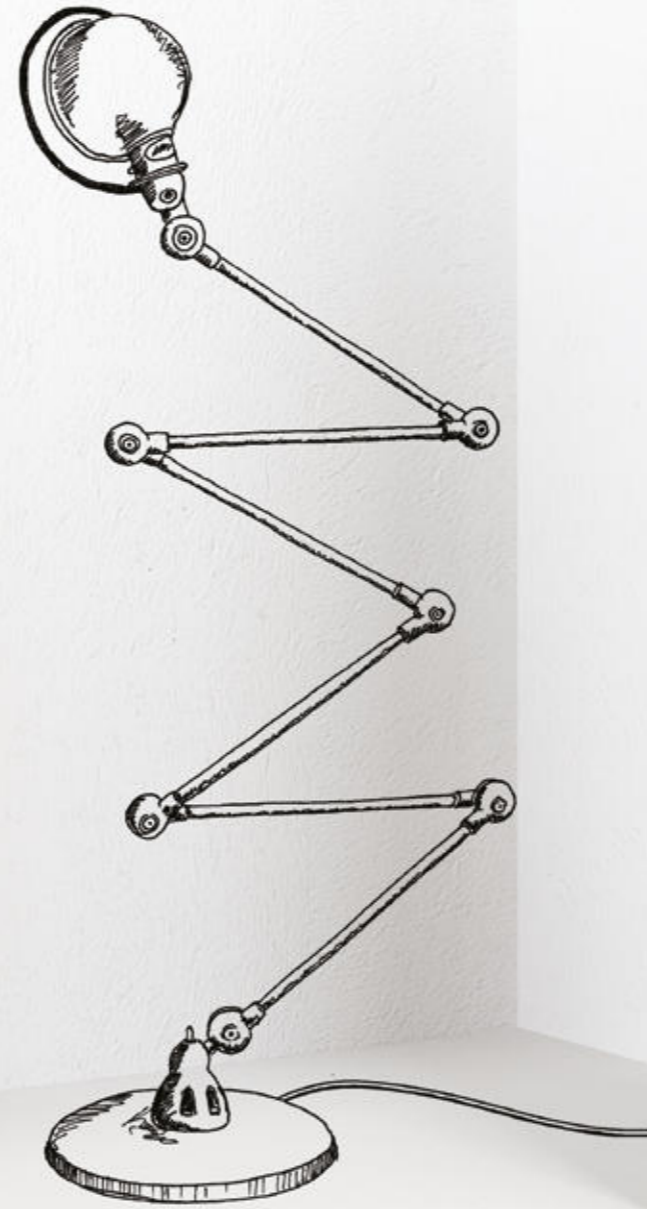



KLING



CON CR ET E

DSH

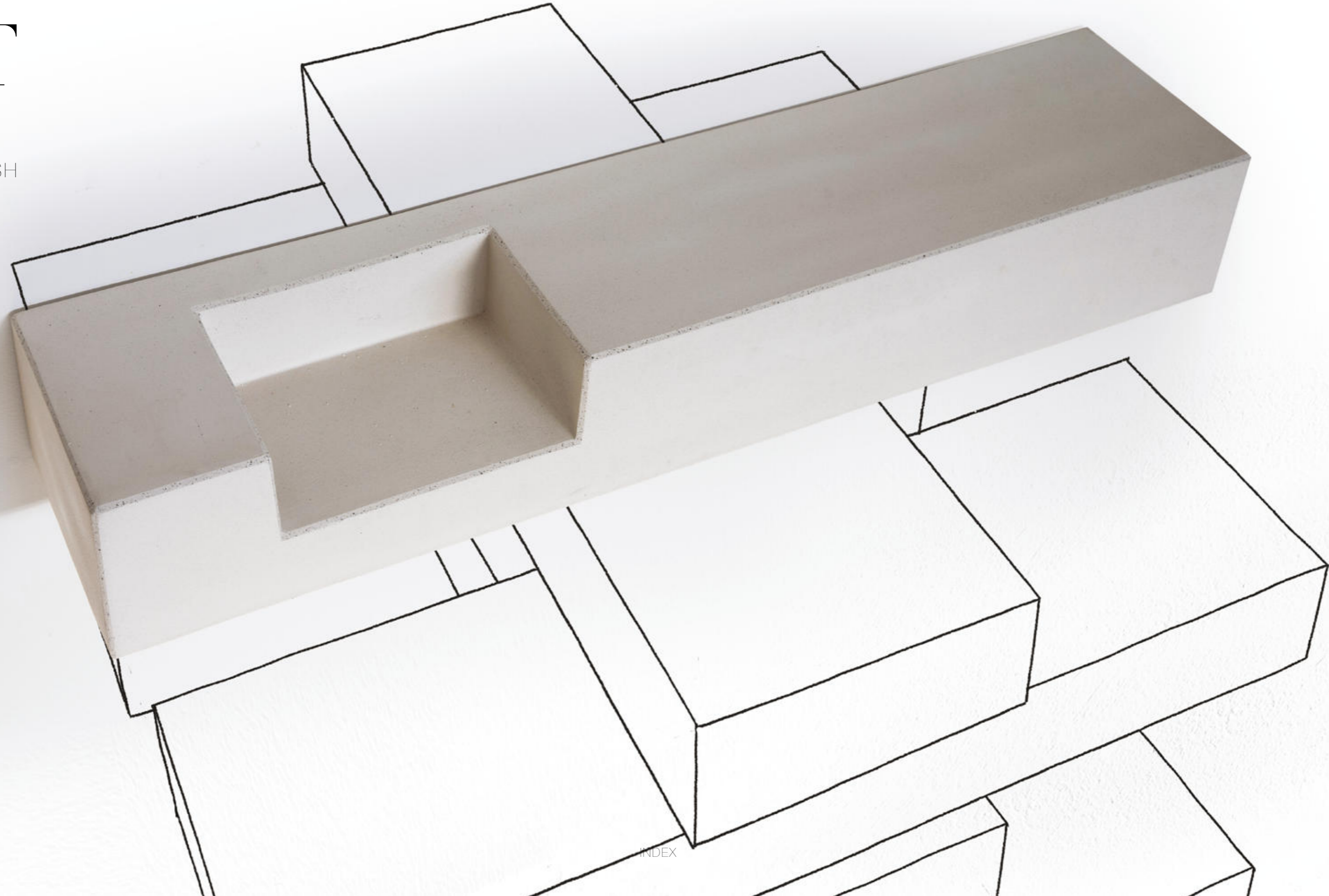

CON
CR
ET
E

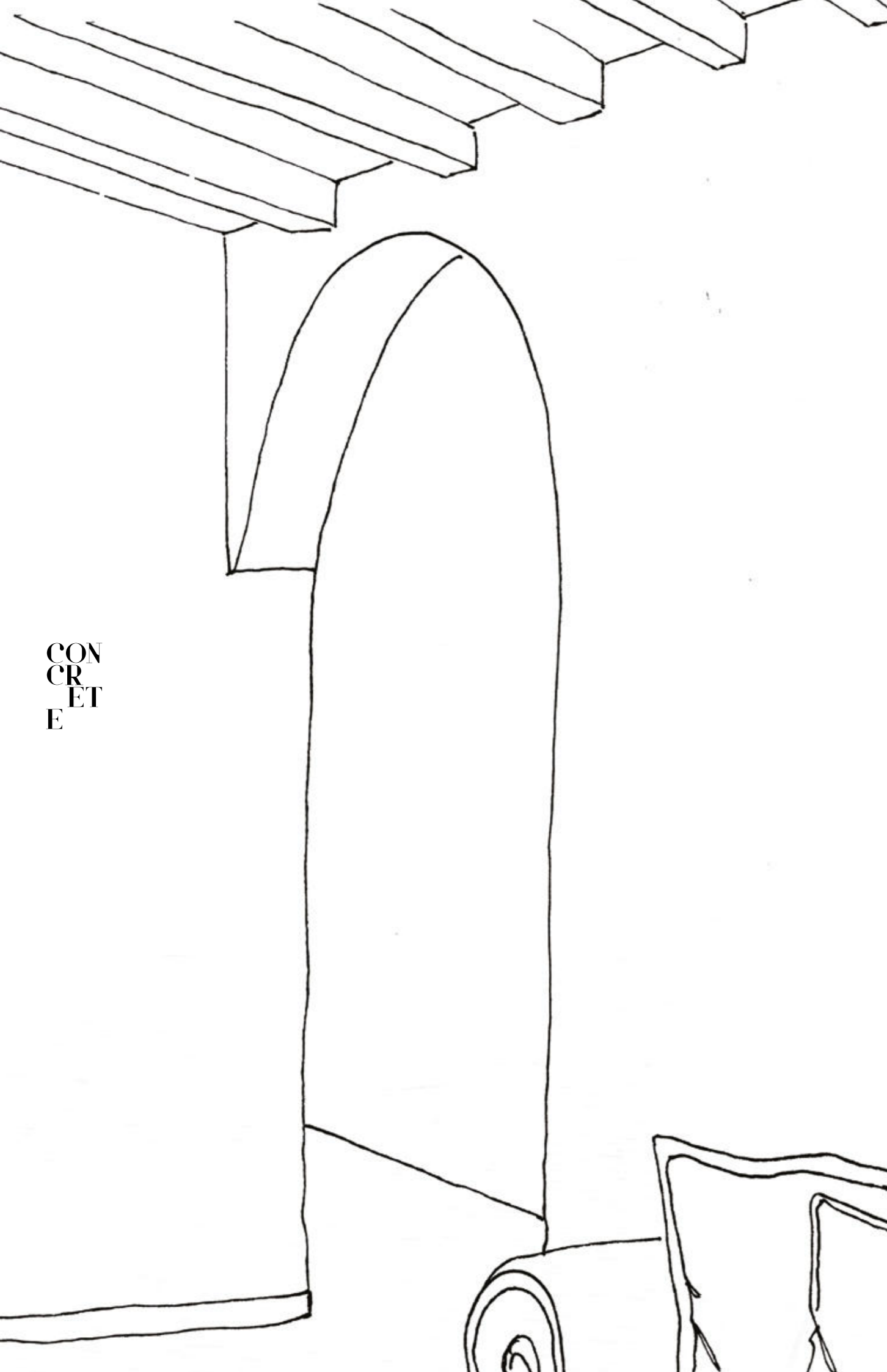

INDEX

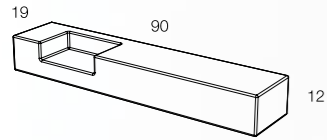







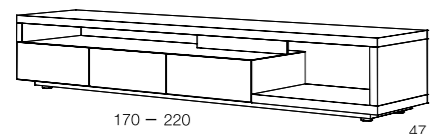
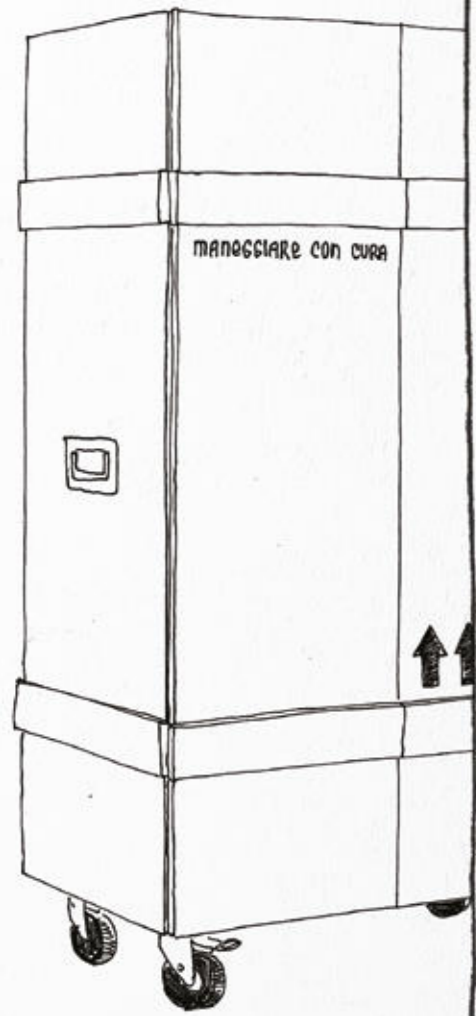

O
DE

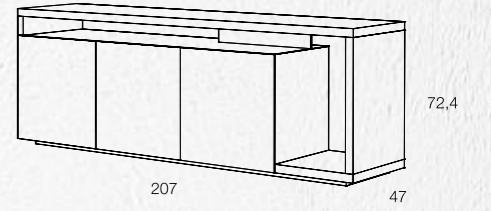

AR
IA

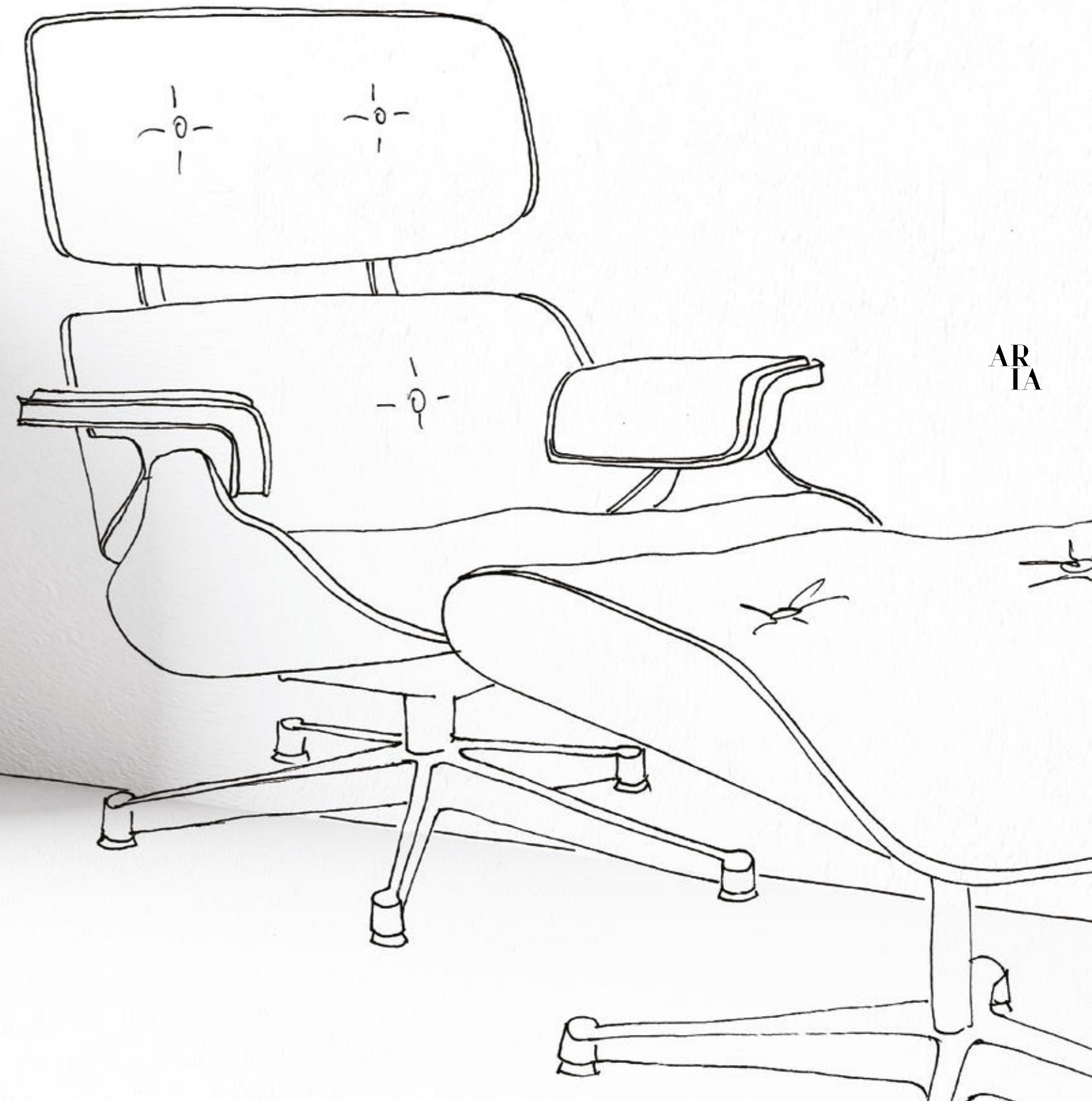

AR
IA

QUE ENS

FERRUCCI & VITALE

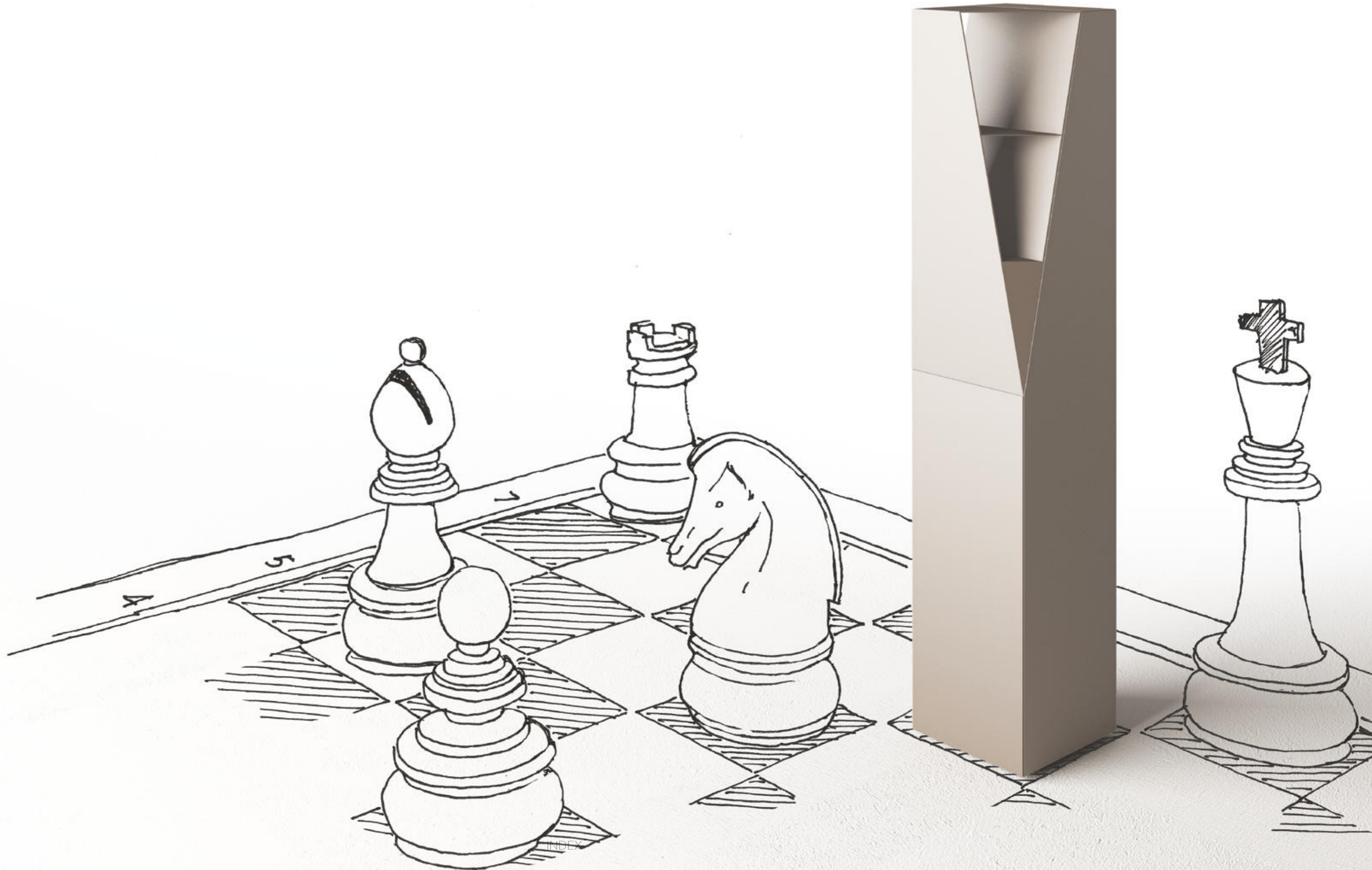

QUE
ENS

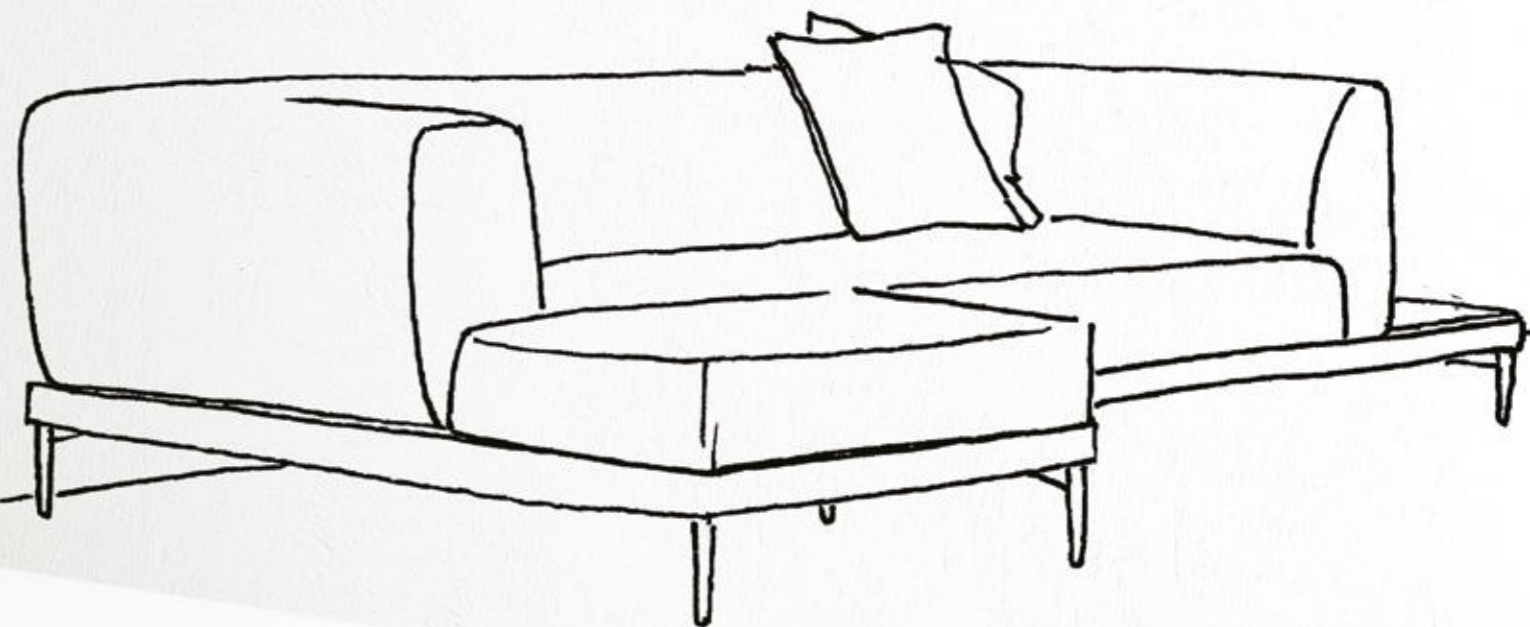
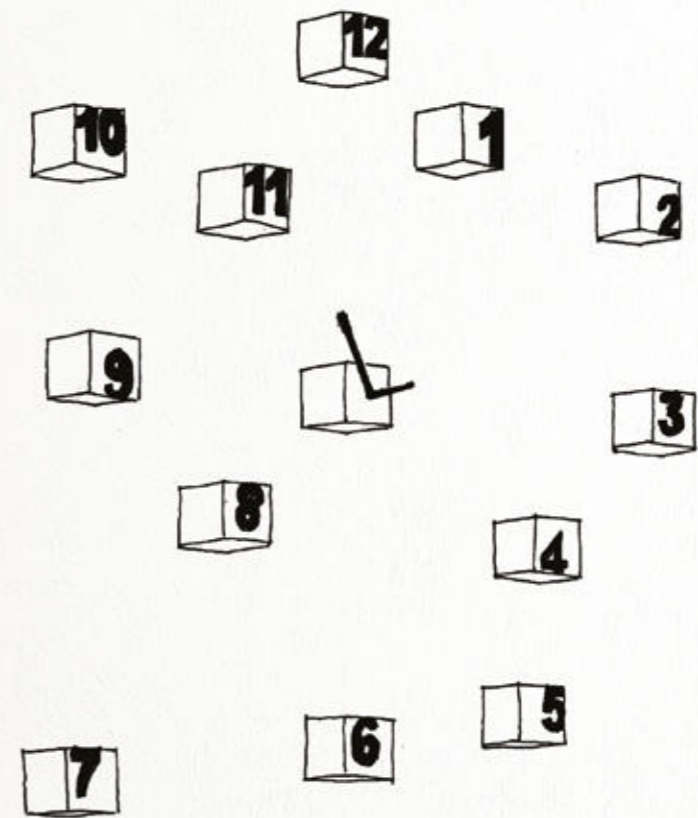

QUE
ENS

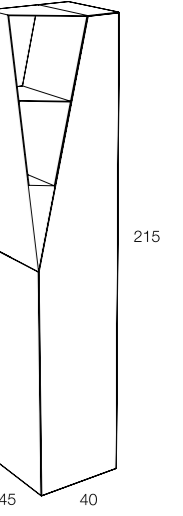
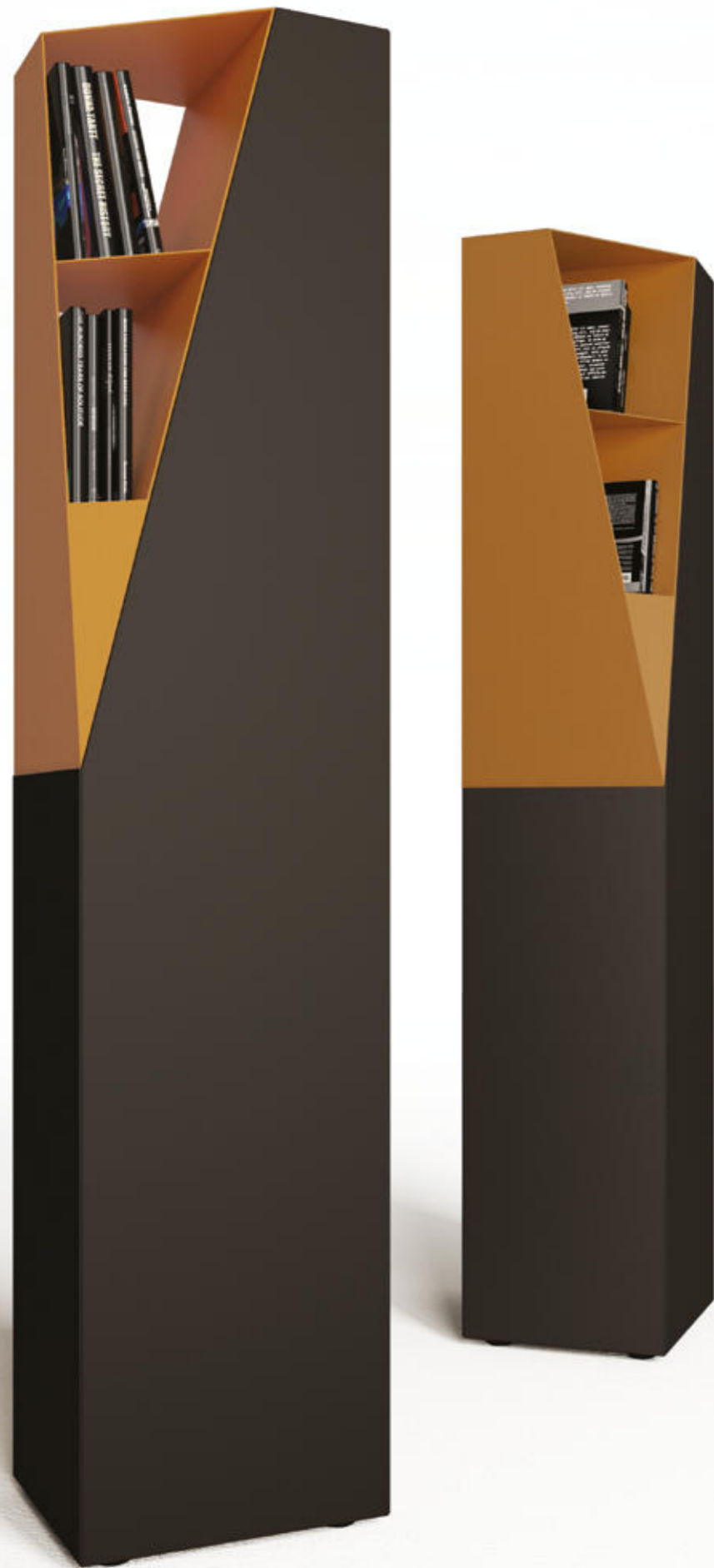

ALTO & TO FRAGILE

CLAUDIO BITETTI

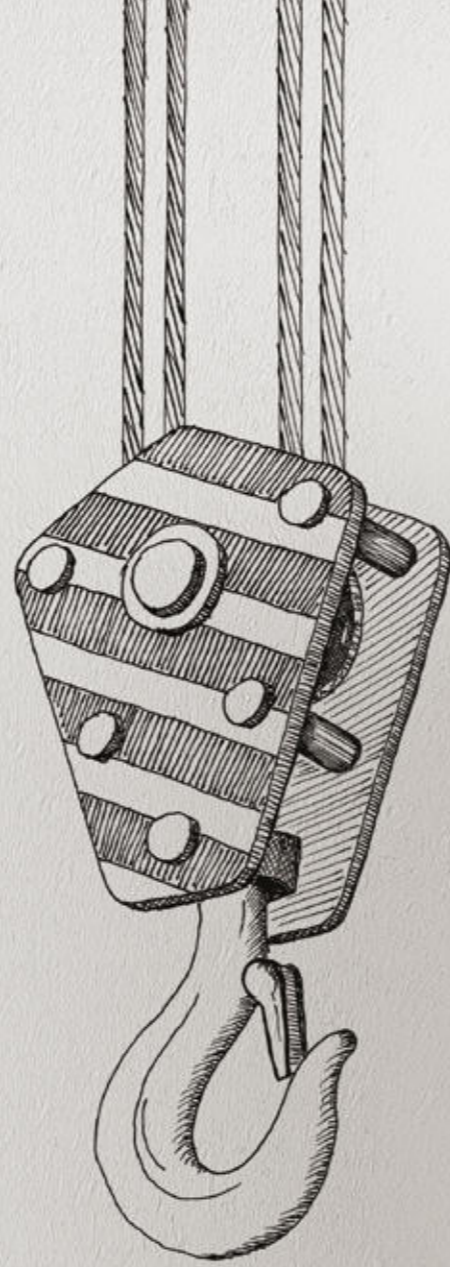

AL
TO

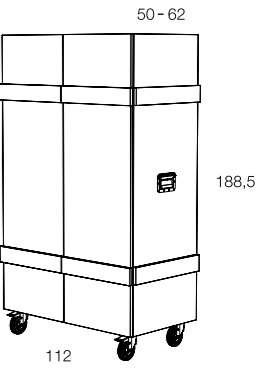

FRA
GI
LE

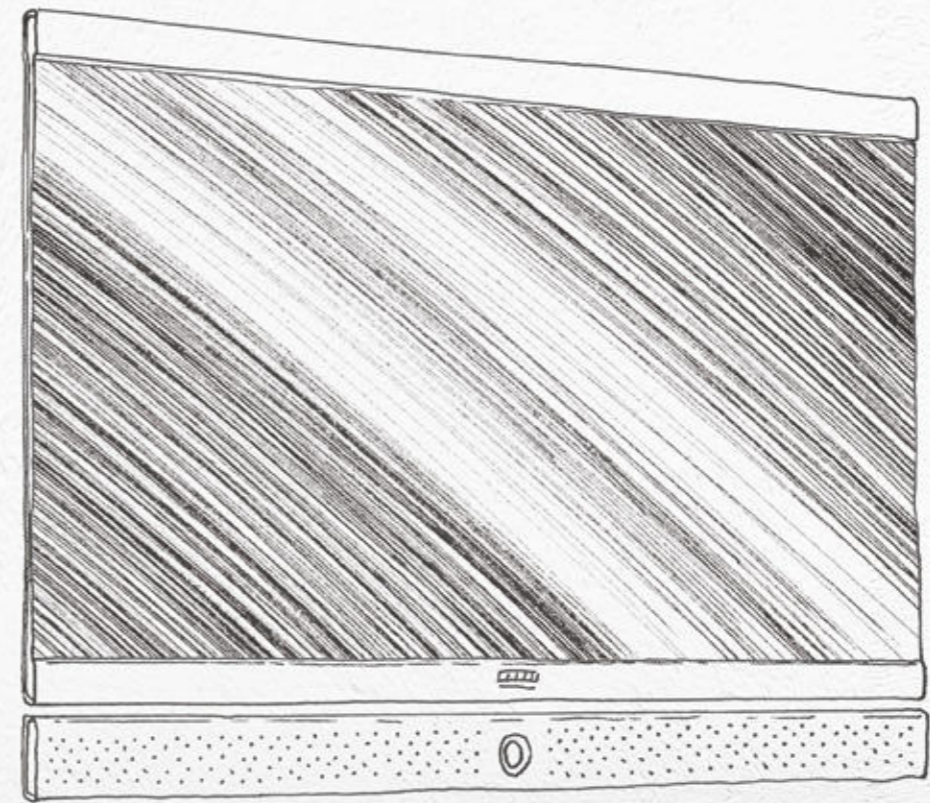
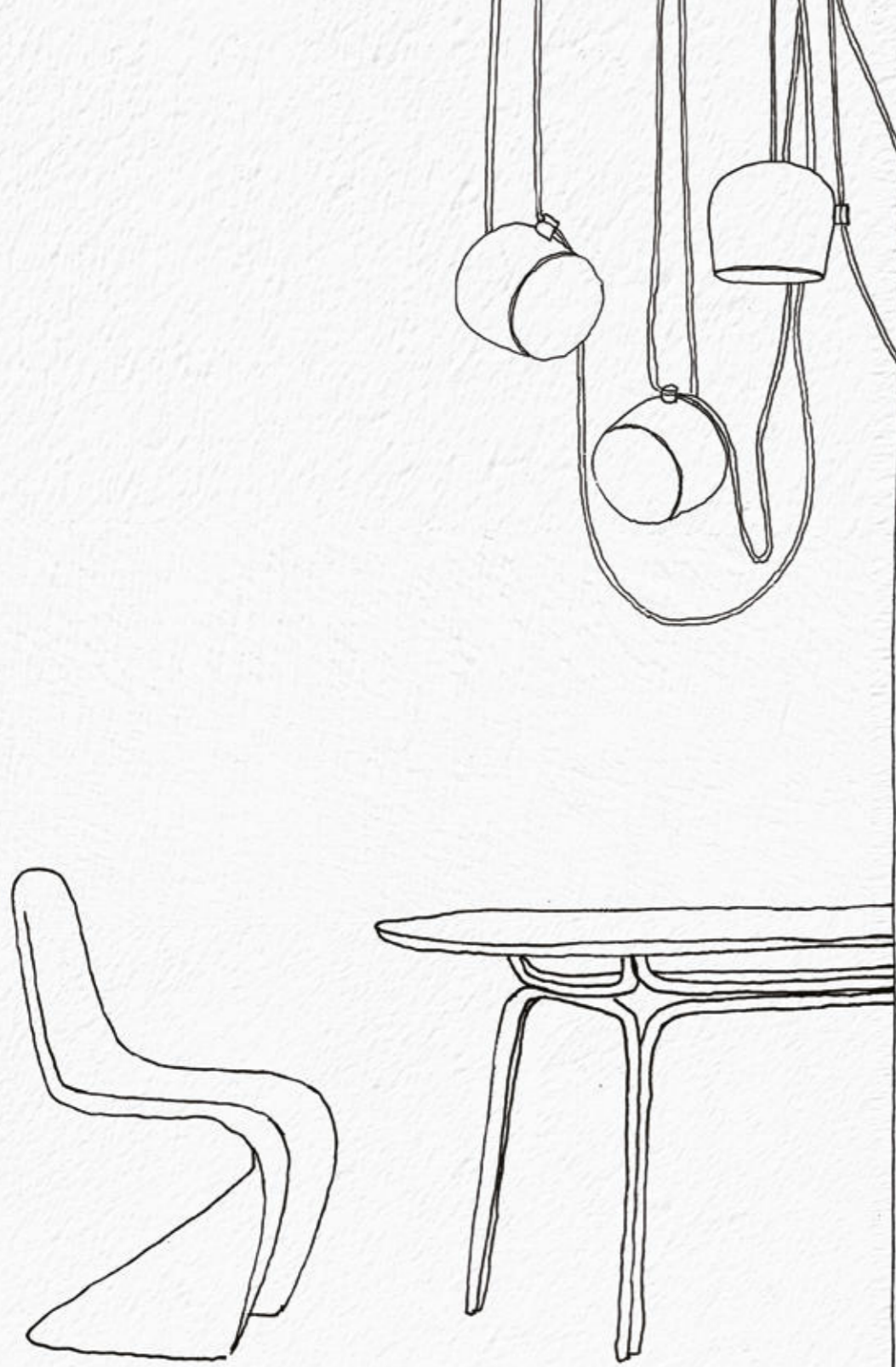

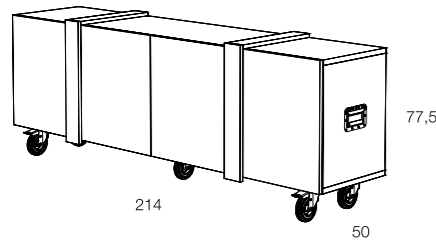





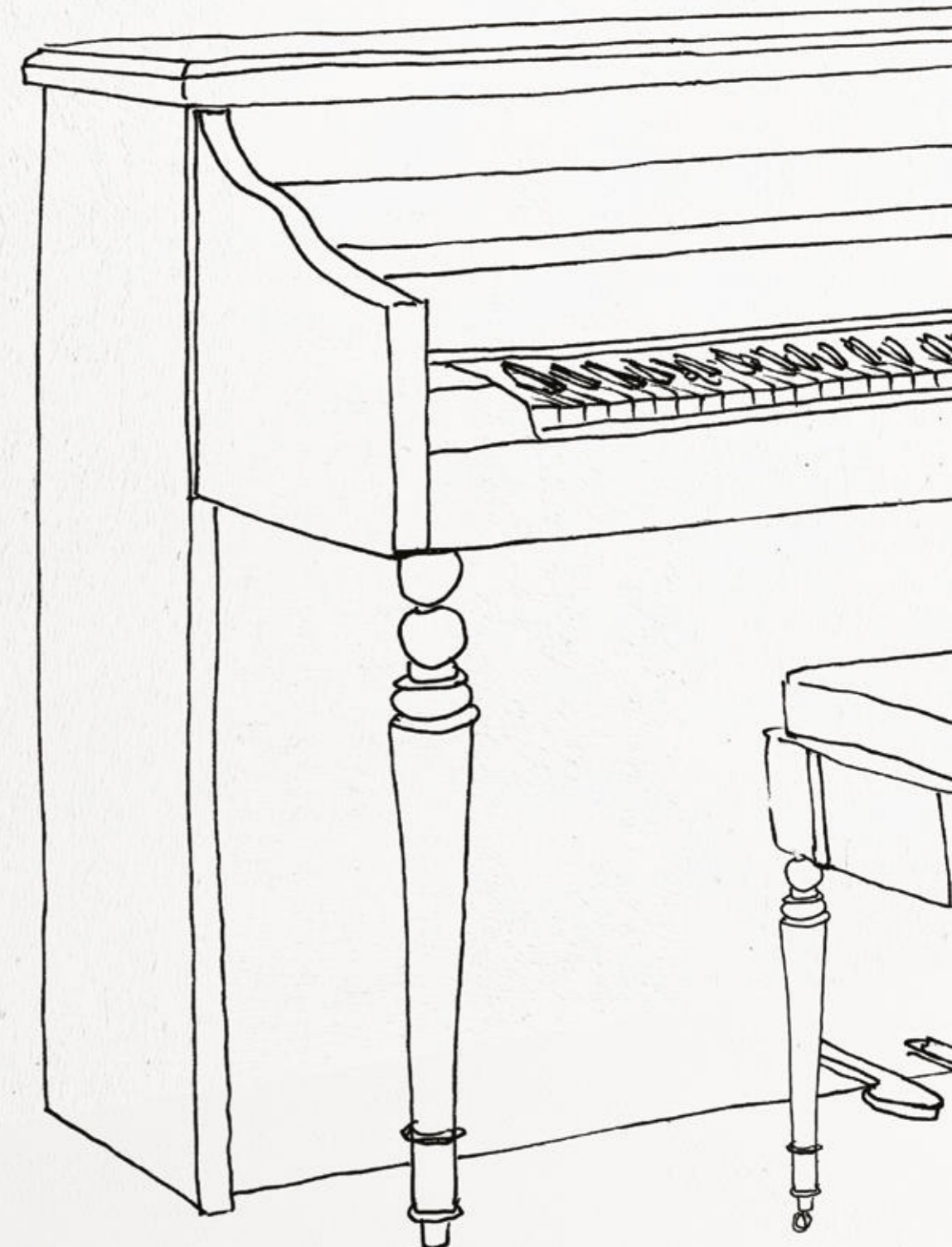





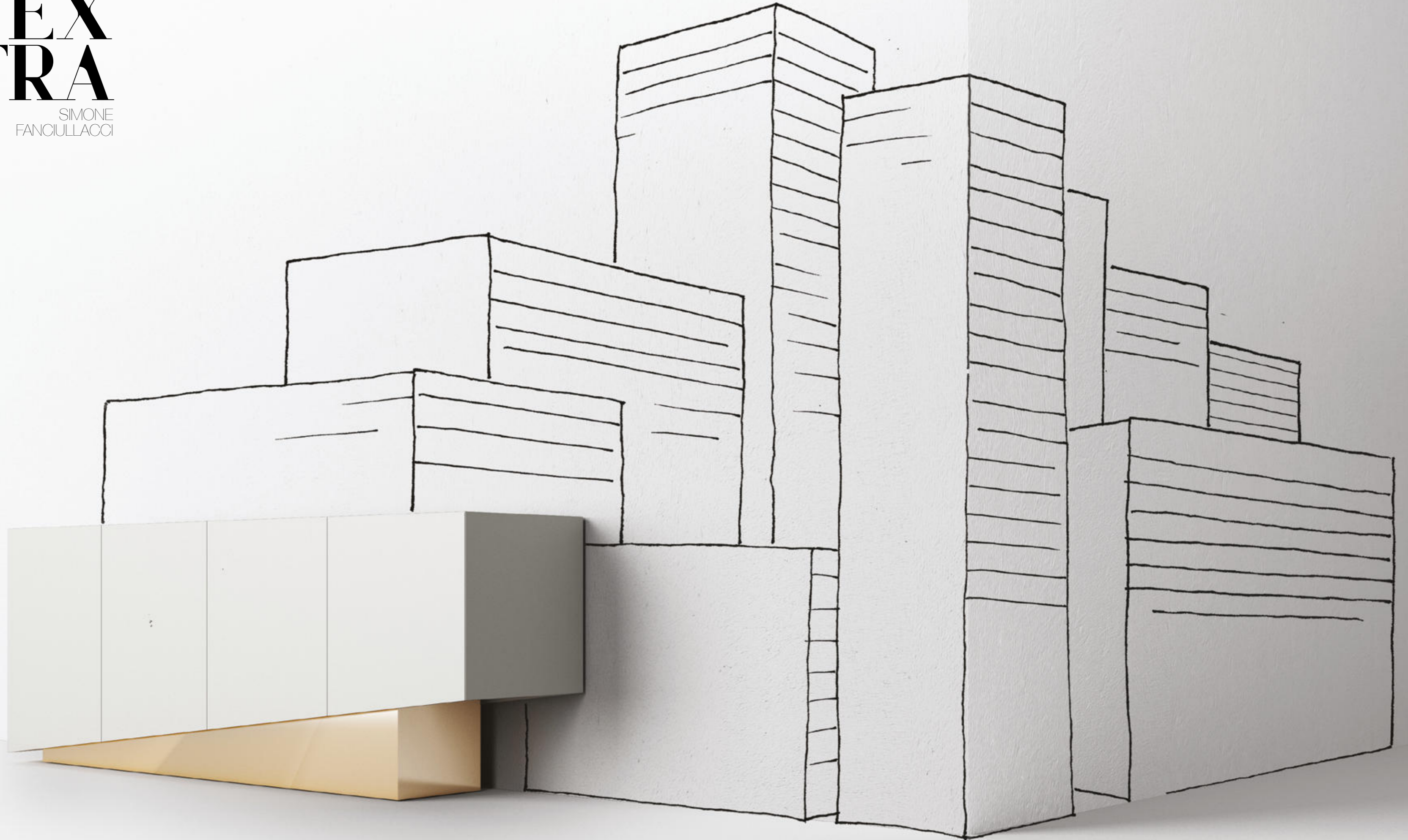

EX
TRA



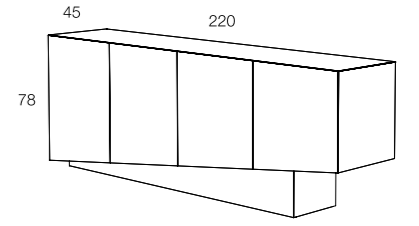

EX
TRA

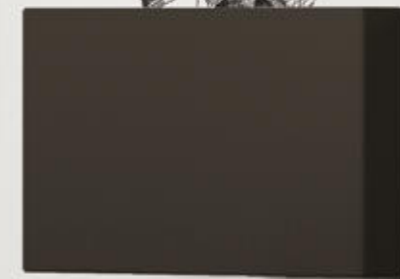
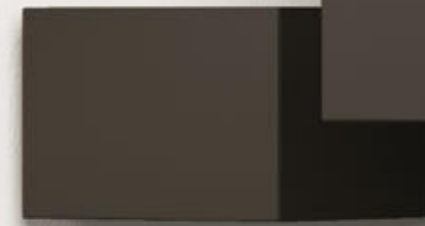





AM BRO GI O

ALBERTO
COLONELLO



AM
BRO
GL
O

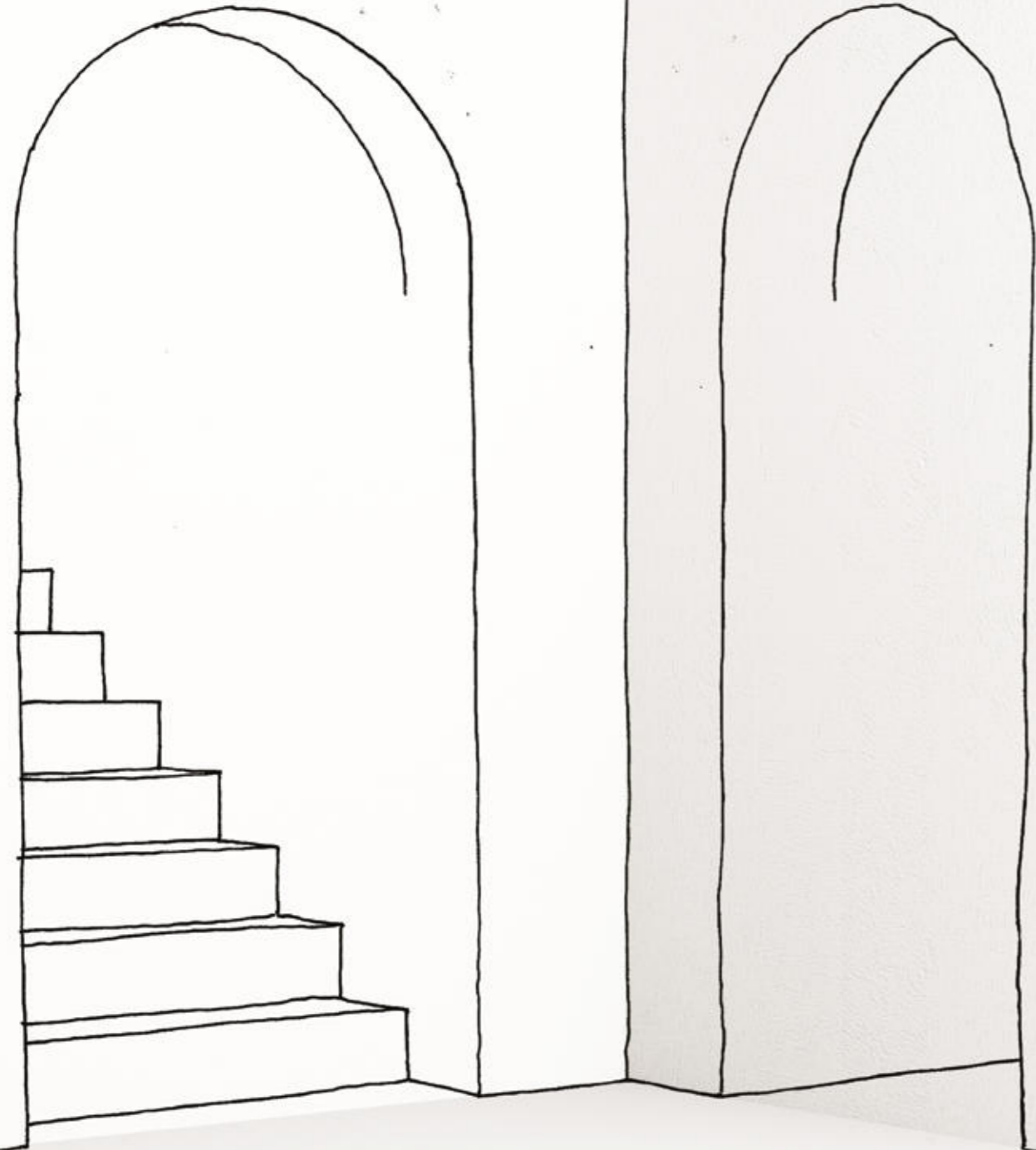

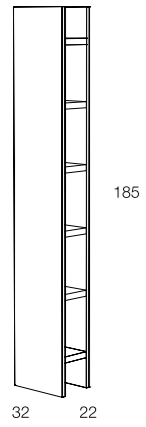

AM
BRO
GL
O

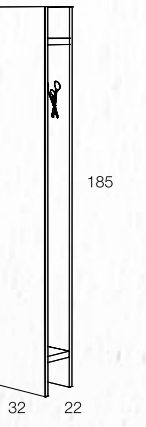

PE PI TE & ME TE O RE

ROBERTO MORA



PE
PI
TE



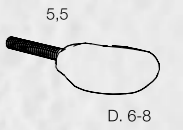

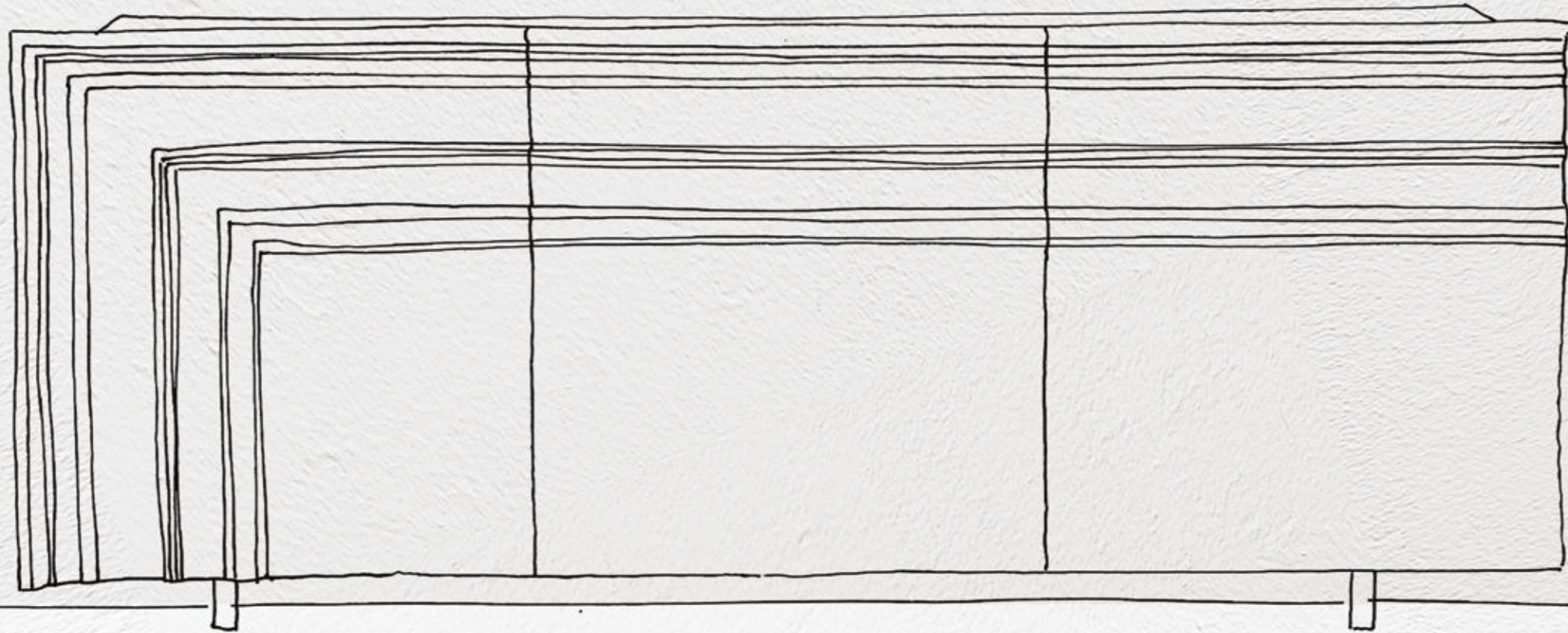





DR
ESS
ME

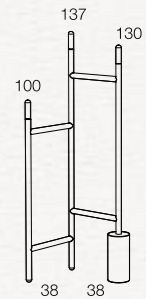

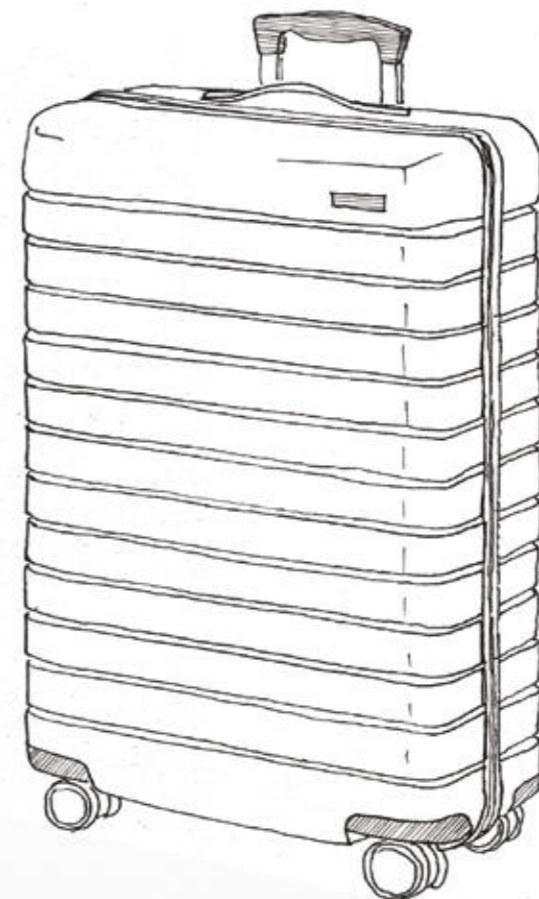

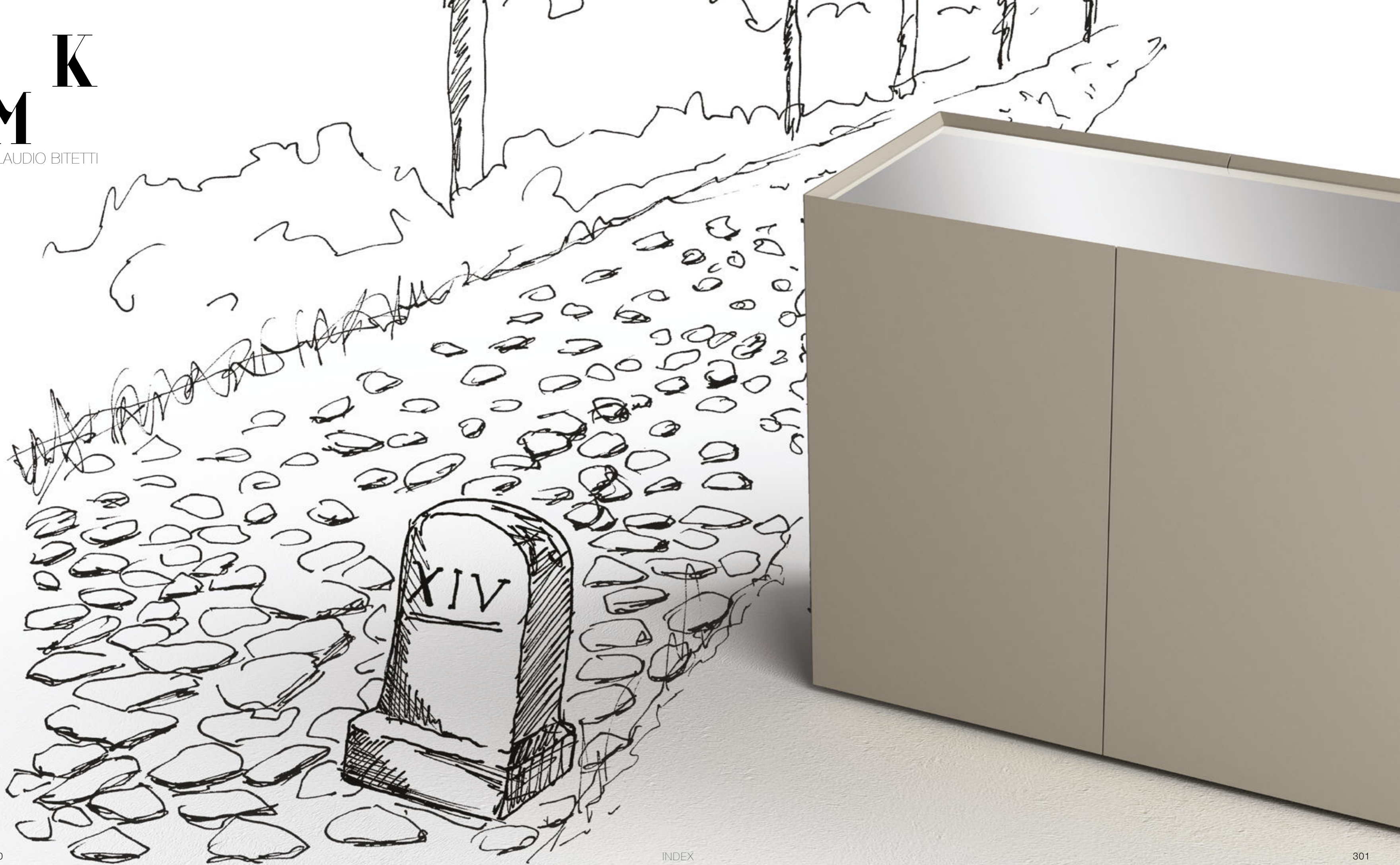



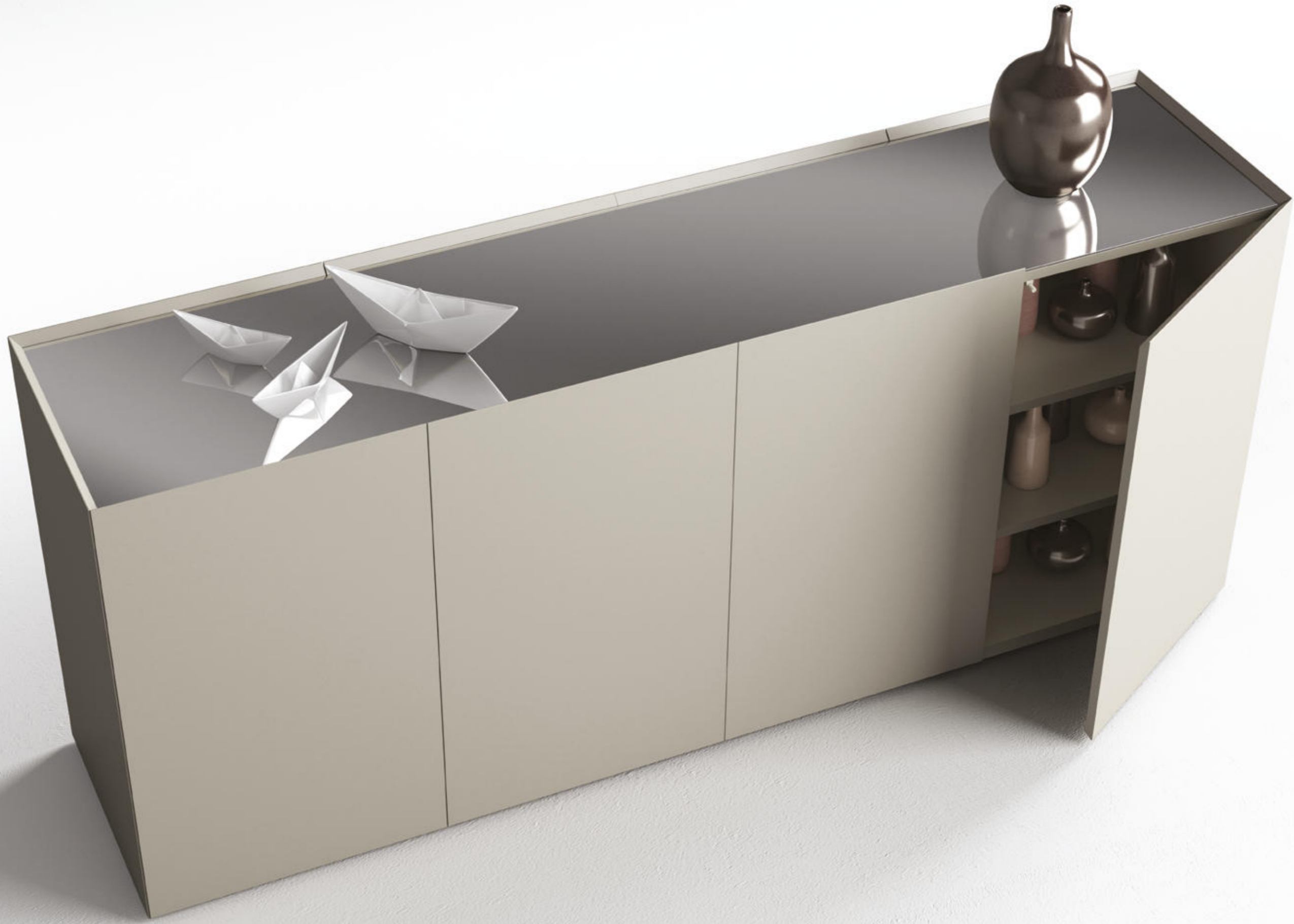
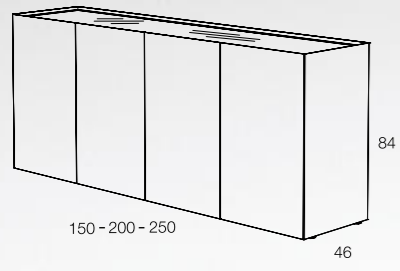

M K



TU BI

SEBASTIANO TOSI







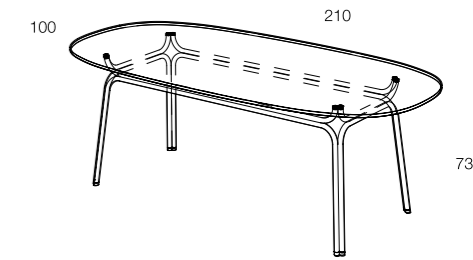



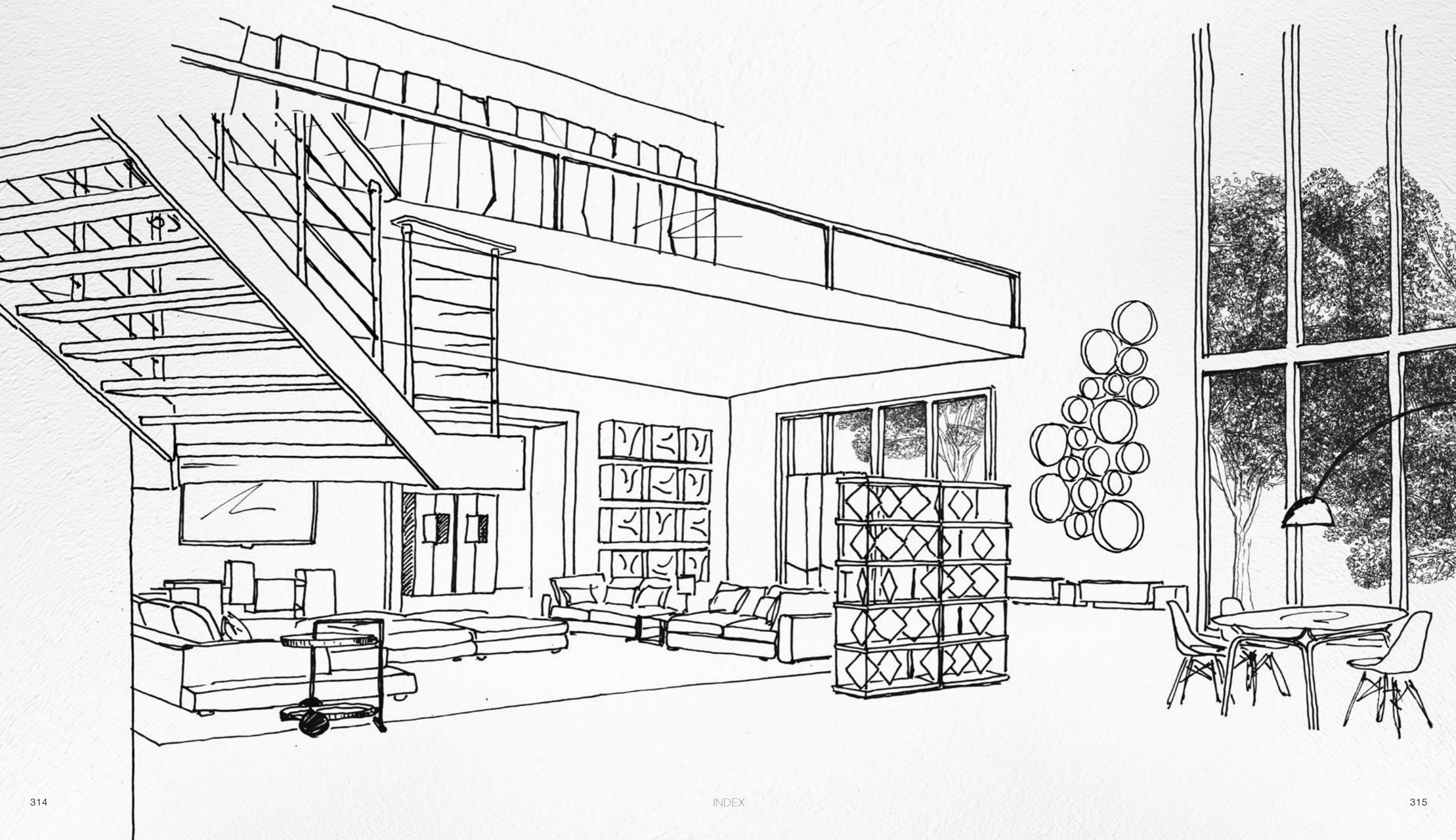













TU
BI



TU
BI



DA TI TE CNI CI TE CH NIC AL DA TA

	LACCATURA GOFFRATA NEI COLORI A CAMPIONARIO <i>EMBOSSSED LACQUERING IN ALL COLORS OF OUR SAMPLE CATALOGUE</i>
	FOGLIA ORO <i>GOLD LEAF</i>
	FOGLIA ARGENTO <i>SILVER LEAF</i>
	OTTONE LUCIDO <i>POLISHED BRASS</i>
	NICHEL LUCIDO <i>POLISHED NICKEL</i>
	OTTONE SATINATO <i>SATIN BRASS</i>
	NICHEL SATINATO <i>SATIN NICKEL</i>
	INOX <i>INOX</i>
	METALLO BIANCO GOFFRATO <i>EMBOSSSED WHITE METAL</i>
	METALLO ANTRACITE GOFFRATO <i>EMBOSSSED ANTHRACITE METAL</i>
	METALLO BIANCO OPACO <i>MATT WHITE METAL</i>
	NICHEL NERO <i>BLACK NICKEL</i>
	SPECCHIO STANDARD <i>STANDARD MIRROR</i>
	SPECCHIO BRONZATO <i>BRONZE MIRROR</i>
	SPECCHIO FUME' <i>SMOKED MIRROR</i>
	APERTURA VASISTAS / RIBALTA <i>OPENING UP/DOWN</i>
	APERTURA DESTRA / SINISTRA <i>OPENING RIGHT/LEFT</i>
	RIPIANO IN CRISTALLO EXTRA CHIARO <i>EXTRA-CLEAR CRYSTAL SHELF</i>
	ESSENZA LARICE SPAZZOLATO / FINITURA LACCATO <i>ESSENCE LARCH BRUSHED / EMBOSSSED LACQUERING</i> <i>IN ALL COLORS OF OUR SAMPLE CATALOGUE</i>

	TEAK OPACO / MDF NERO <i>MATT TEAK / BLACK MDF</i>
	CEMENTO BIANCO <i>WHITE CONCRETE</i>
	CEMENTO GRIGIO <i>GREY CONCRETE</i>
	LED LUCE BIANCA CALDA / FREDDA (3000/6000 K) <i>WARM / COLD WHITE LIGHT LED (3000/6000 K)</i>
	LED LUCE CALDA 4 CANALI (RGB WW) <i>FOUR CHANNEL WARM LED LIGHT (RGB WW)</i>
	MODULO DESTRO / SINISTRO <i>UNIT RIGHT/LEFT</i>
	FISSAGGIO A PARETE <i>WALL FIXING</i>
	ASSEMBLARE <i>ASSEMBLING</i>
	VOLUME <i>VOLUME</i>
	NUMERO DI COLLI <i>NUMBER OF PACKAGE</i>
	PESO <i>WEIGHT</i>

Contenitori in agglomerato di legno a 2 ante battenti completo di maniglie e ruote industriali (h. 15 cm con freno).
Superfici esterne in legno di larice spazzolato. Finitura gofrata nei colori a campionario.
Disponibile in versione armadio con tubo appendiabiti (profondità 62 cm) e versione contenitore a ripiani spostabili (profondità 50).
Containers in composite wood with 2 hinged doors provided with handles and industrial wheels (h. 15 cm with braking mechanism). External surfaces in brushed larch, embossed finishing in all colours of our sample catalogue.
Available as cabinet version with 1 bar for clothes hanger (depth 62 cm) and as container with removable shelves (depth 50)

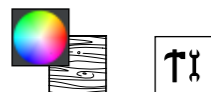

ALTO 50

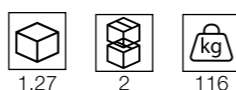
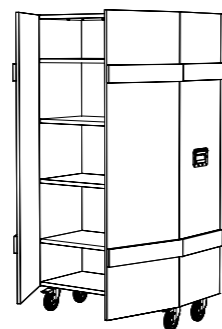
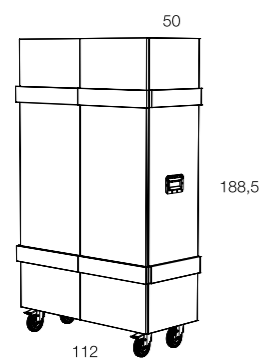

ALTO 62

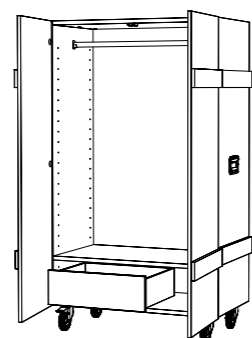
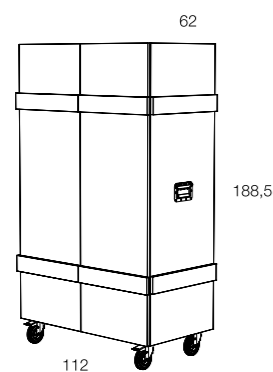

OPZIONE: KIT 3 RIPIANI
KIT CASSETTO
OPTIONAL: KIT 3 SHELVES
KIT 1 DRAWER

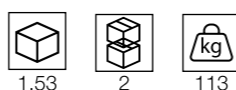

Credenza in agglomerato di legno a 4 ante battenti completo di maniglie e ruote industriali (h. 15 cm con freno), 2 ripiani interni spostabili, superfici esterne in legno di larice spazzolato, finitura gofrata nei colori a campionario.
Sideboard in composite wood with 4 hinged doors provided with handles and industrial wheels (h. 15 cm with braking mechanism), 2 inside removable shelves, external surfaces in brushed larch, embossed finishing in all colours of our sample catalogue.

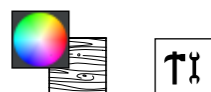

FRAGILE 50

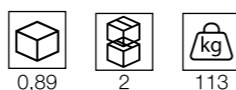
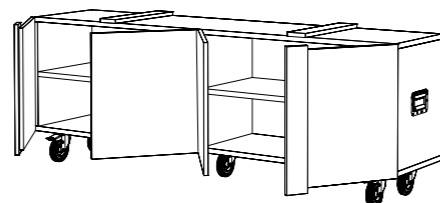
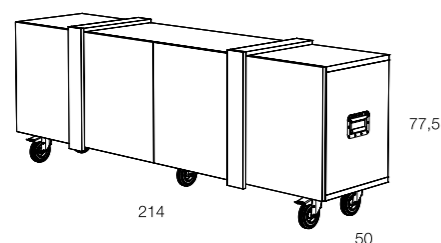

Contenitore a parete in agglomerato di legno, anta e spalla a specchio. Interno in finitura gofrata nei colori a campionario. Disponibile in 2 versioni: appendiabiti e ripiani (6 fissi). Il senso dell'apertura della porta si determina al momento del montaggio a parete.
Wall mirror container in composite wood, door and side in mirror, inside in embossed finishing in all colours of our sample catalogue. Available in 2 versions: coat hanger and with shelves (6 fixed shelves). The opening of the door can be chosen during the assembling.



AMBROGIO
RIPIANI / SHELVES

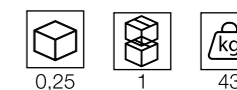
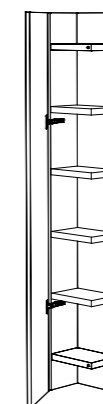
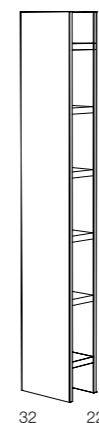

AMBROGIO
APPENDIABITI / CLOTHES HANGERS

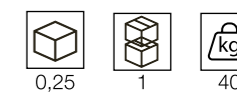
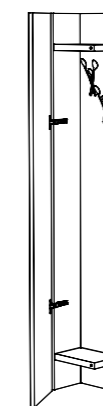
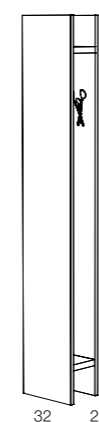

Contenitore pensile pentagonale, ideato per composizioni angolari, in agglomerato di legno con anta battente.
 Finitura gofrata nei colori a campionario.
Pentagonal wall case, designed for corner compositions, in composite wood with hinged door.
Embossed finishing in all colours of our sample catalogue.



ANG 39

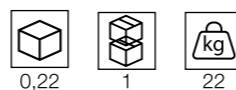
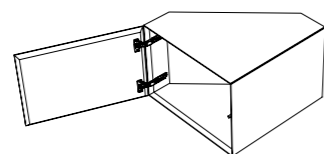
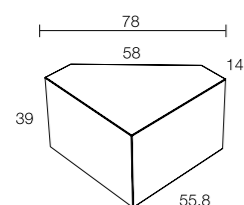

ANG 64

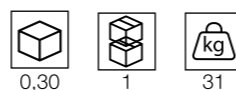
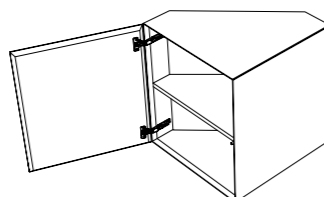
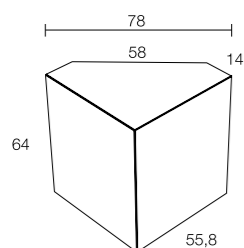

Contenitori porta tv in agglomerato di legno a 2 o 3 cassetti. Finitura gofrata nei colori a campionario.
 Contenitore e cornice possono avere colori diversi.
Tv sideboard in composite wood with 2 or 3 drawers, embossed finishing in all colours of our sample catalogue.
Container and frame can have different colours.



ODE 220

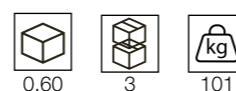
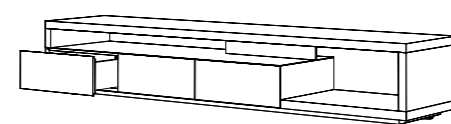
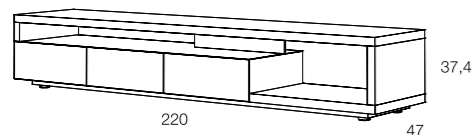

ODE 170

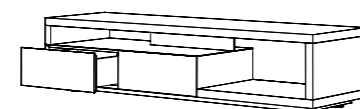
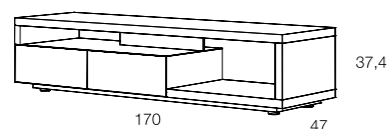

Credenza in agglomerato di legno a 3 ante battenti e 3 ripiani spostabili. Finitura gofrata nei colori a campionario, contenitore e cornice possono avere colori diversi.
 Il contenitore ad ante puo' essere in finitura gofrata nei colori a campionario, in finitura foglia argento e foglia oro.
Sideboard in composite wood with 3 hinged doors and 3 removable shelves, embossed finishing in all colours of our sample catalogue, container and frame can have different colours.
The container can be in embossed finishing in all colours of our sample catalogue, in gold leaf and silver leaf finishing.



ARIA

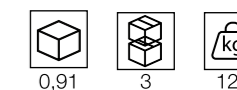
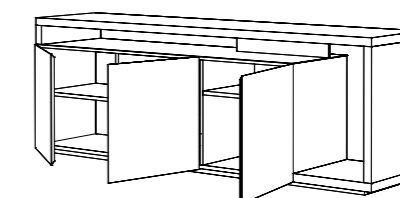
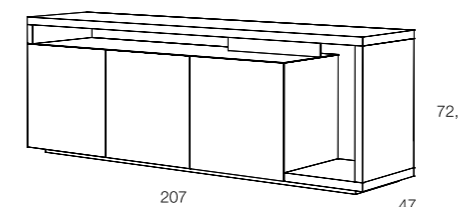

Carrelli / tavolini in metallo. Finitura gofrata in colore antracite, ripiano a specchio bronzato o fumè. Ruote anti-traccia e antirumore in nylon nero.
Service tables / coffee tables in metal, embossed finishing in antracite colour, mirrored shelves bronze or fumè.
Anti-tracking and anti-noise wheels in black nylon.

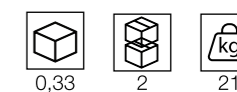
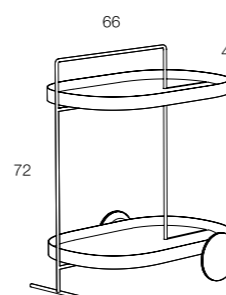
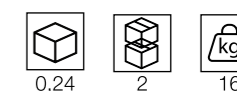
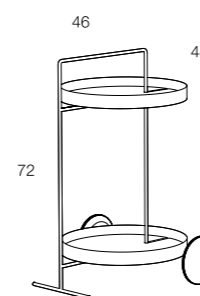

BETTY

Specchio a parete, struttura in agglomerato di legno con 4 appendini (removibili) e 5 cassetti in metallo colore blanc, sistema di fissaggio a parete incluso. I cassetti si estraggono totalmente da entrambe i lati.

Wall mirror, structure in composite wood with 4 coat-hanger hooks (movable) and 5 metal drawers in blanc colour, wall fixing system is included, total extraction of the sliding drawers from both sides.

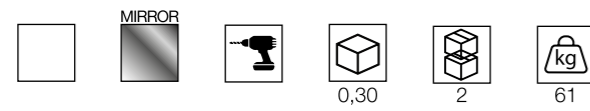

BROOKLYN

Credenza composta da contenitori in agglomerato di legno ad ante battenti, lavorazione a 45° sui 4 lati, 4 ripiani interni spostabili in cristallo extra - chiaro, piedini altezza 2 cm regolabili. Finitura gofrata nei colori a campionario.

Inserti in metallo finitura gofrata nei colori a campionario. Contenitori ed inserti possono avere colori diversi.

Sideboard composed by containers in composite wood with hinged doors, with a 45° finish on 4 sides, 4 internal removable shelves in extra-clear crystal-glass, h.2 cm. adjustable feet. Embossed finishing in all colours of our sample catalogue.

Metal spacers embossed finishing in all colours of our sample catalogue, the containers and the spacers can have different colours.

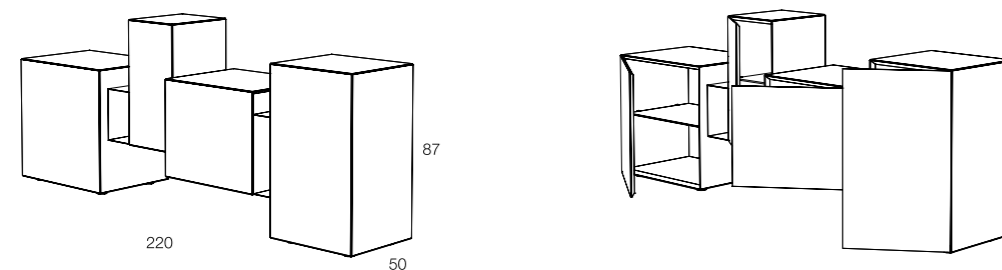
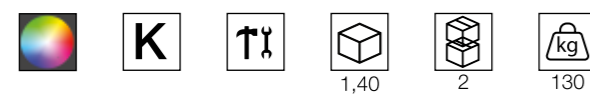

CANTO

Contenitore pensile in agglomerato di legno con anta vasistas o ribalta. Finitura gofrata nei colori a campionario. La spalla esterna obliqua puo' essere a specchio.

Wall case in composite wood with vasistas or flap door. Embossed finishing in all colours of our sample catalogue. The external inclined side can be mirrored.

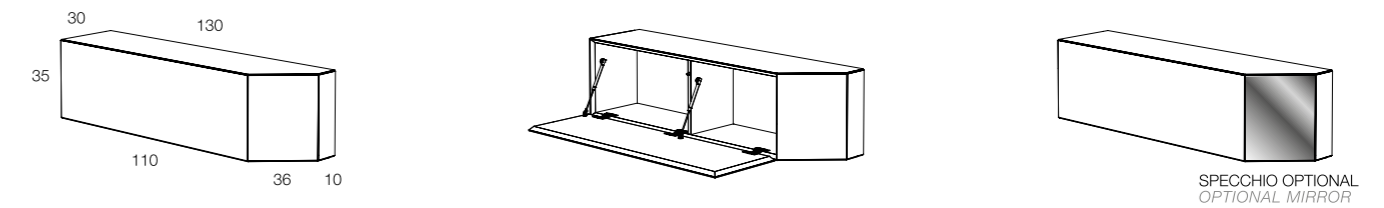
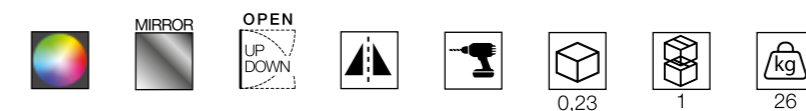

CHIODO FISSO

Chiodo appendiabito in fusione di ottone cromato.

Nail Clothes Hanger In Fusion Of Chromed Brass



CHIODO FISSO

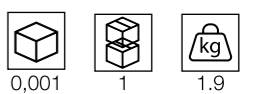
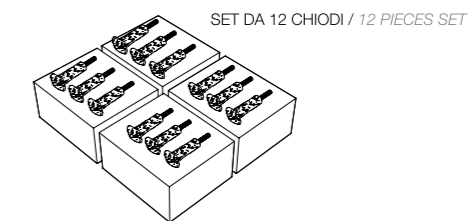
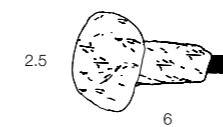

Specchio a parete con 4 appendiabiti chiodo fisso (cromati). La posizione dei chiodi sullo specchio è fissa.

Wall mirror with 4 coat-hanger nails (chromed). The nails on the mirror have a fixed positioning.



SPECCHIO CHIODO FISSO 50
MIRROR CHIODO FISSO 50

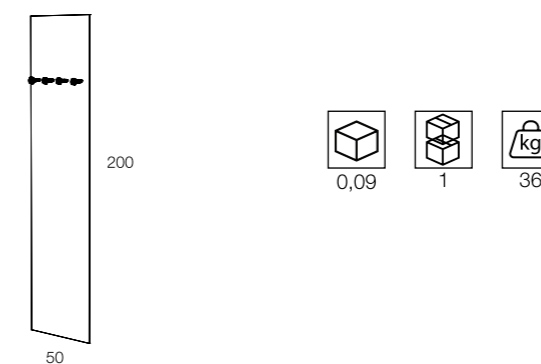

SPECCHIO CHIODO FISSO 85
MIRROR CHIODO FISSO 85

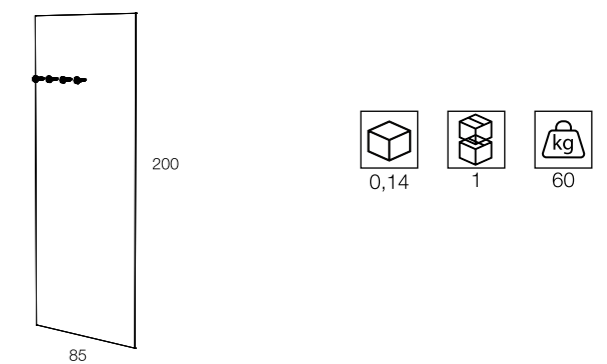

CLEOPATRA

Libreria verticale autoportante completa di 10 ripiani in metallo verniciato a polveri termoindurenti, colore bianco finitura opaco (non goffrato), base acciaio inox - mirror. I ripiani ruotano di 360° attorno alla struttura verticale. Disponibile con cassetti svuotatasche (multipli di 2).

Free-standing vertical bookcase with 10 shelves in painted metal, coated with thermosetting powders white colour matt finishing (not embossed), base in inox steel - mirror. Revolving shelves 360° around the vertical structure, available with drawers empty-pockets (multiple of 2).



CLEOPATRA
10 RIPIANI / 10 SHELVES

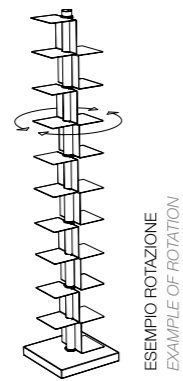
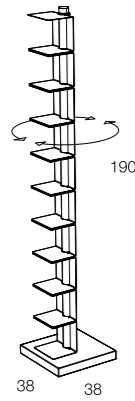

ESEMPIO ROTAZIONE
EXAMPLE OF ROTATION



CLEOPATRA
8 RIPIANI - 2 CASSETTI / 8 SHELVES - 2 DRAWERS

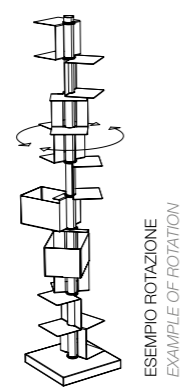
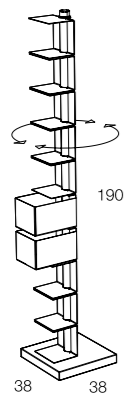

ESEMPIO ROTAZIONE
EXAMPLE OF ROTATION



CONCRET

Mensola in cemento fibrorinforzato ad alta resistenza. Finitura sabbato fine, disponibile in colore cemento bianco e cemento grigio. Il materiale è sottoposto a trattamento oleo ed idrorepellente. Sistema di fissaggio a parete incluso.

Shelf in fiber-reinforced cement, at high resistance, with fine sandblasted finishing, available in white and grey cement colour. The material undergoes an oil and hydro-repellent treatment. Wall fixing system included.

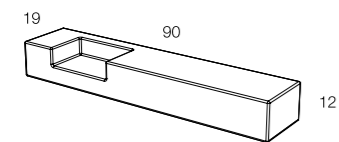
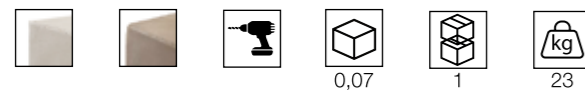

DOROTEA

Contenitori (credenza / madia) con ante battenti e spalle in agglomerato di legno in pasta nera, lavorate a sezioni triangolari con effetto tridimensionale, superfici esterne in legno di teak, finitura trasparente opaca. Disponibile con zoccolo nero altezza 3 cm o piedini altezza 10 cm in metallo satinato colore ottone o nichel. Struttura interna finitura goffrata colore noir.



DOROTEA
CREDENZA / SIDEBOARD

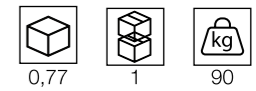
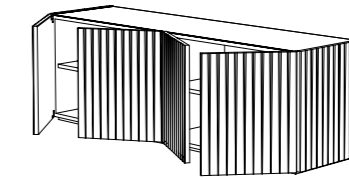
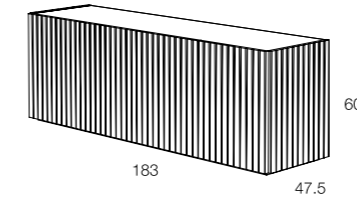

DOROTEA
MADIA / HIDE CONTAINER

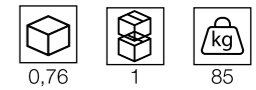
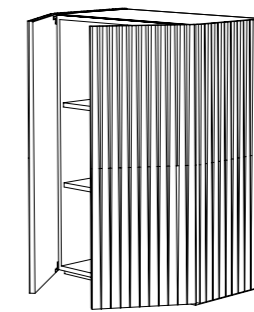
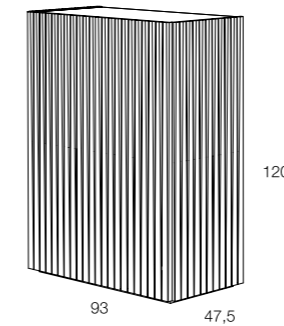

DR ESS ME

Servomuto in tubolare di ferro. Finitura goffrata in colore antracite, inserti in metallo satinato colore nichel e ottone verniciato. La struttura si puo' completare con specchio e piano d'appoggio (optional), nei medesimi colori degli inserti.

Valet stand in iron tubular, embossed finishing antracite colour, metal satin inserts colour nickel and brass.

The structure can be completed with the mirror and the support top (optional) in the same colours of the inserts.

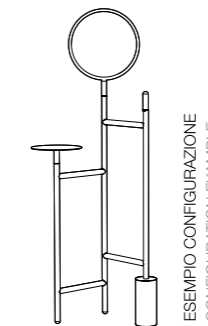
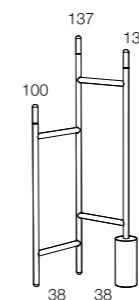

ESEMPIO CONFIGURAZIONE
CONFIGURATION EXAMPLE

OPTIONAL SPECCHIO / OPTIONAL MIRROR

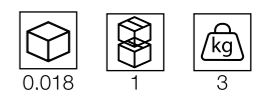
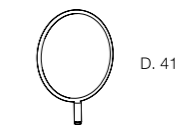

OPTIONAL VASSOIO / OPTIONAL SUPPORT TOP

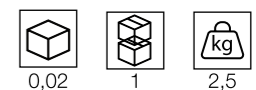

EXTRA

Credenza in agglomerato di legno a quattro ante, ripiani interni in cristallo extrachiario regolabili in altezza, disponibile in finitura gofrata nei colori a campionario, basamento satinato in due colori: ottone e nichel.

Sideboard with 4 doors in composite wood, internal shelves in extra clear crystal glass, adjustable in height, available in an embossed finishing in all colours of our sample catalogue, satin base in two colours: brass and nickel.

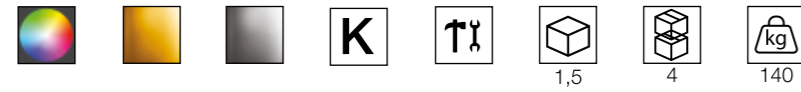

FORMOSA

Contenitore in agglomerato di legno con 1 anta battente, 2 cassetti interni e 5 ripiani di cui 3 spostabili, piedini altezza 2 cm regolabili. Finitura gofrata nei colori a campionario e finitura foglia argento e foglia oro.

Il contenitore necessita il fissaggio a parete, possibilità di inserire kit illuminazione a led.

Free-standing column container in composite wood with 1 hinged door, 2 internal drawers and 5 shelves, 2 of them removable, h.2 cm adjustable feet, embossed finishing in all colours of our sample catalogue and in silver leaf and gold leaf finishing. The container needs to be fixed on the wall; a lighting system can be inserted (rgb led kit).



IN PIEDI

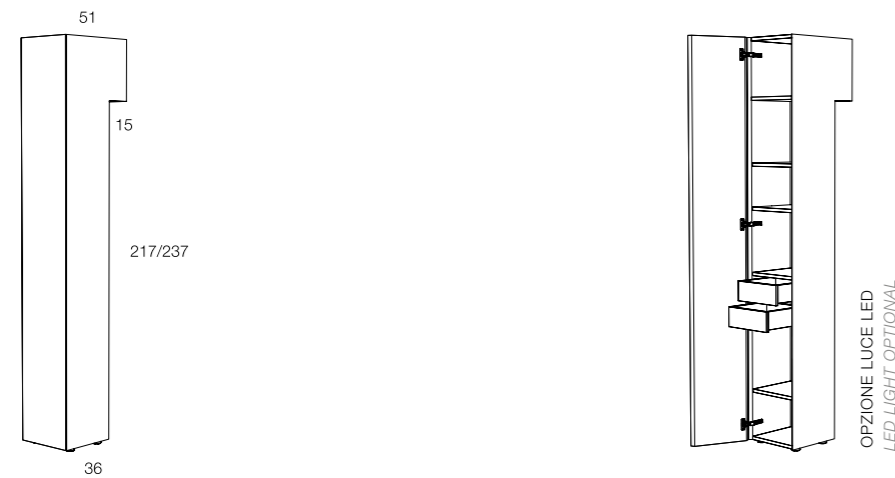

FORMOSA

Colonna con struttura in tubolare di ferro (14 mm x 14 mm) in finitura gofrata colore antracite, 6 ripiani e coperchio in finitura gofrata nei colori a campionario. Possibilità di inserire contenitori girevoli in agglomerato di legno, in finitura gofrata nei colori a campionario. La colonna necessita il fissaggio a parete.

Column with frame in iron tubular (14 mm x 14 mm) embossed finishing colour antracite, 6 shelves and top in embossed finishing in all colours of our sample catalogue. Possibility of inserting revolving containers in composite wood, in embossed finishing in all colours of our sample catalogue. The column needs to be fixed on the wall.



ESSENZA

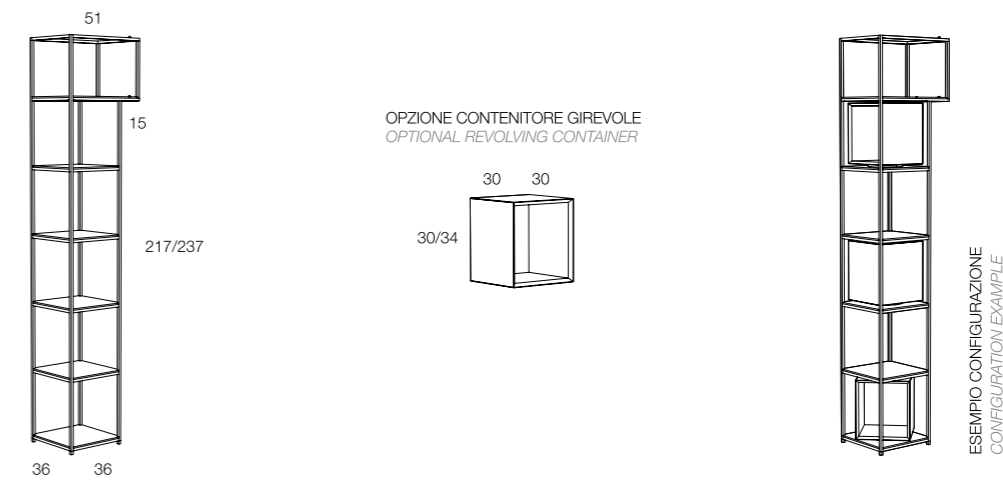

Contenitore porta - tv in agglomerato di legno con 1 anta battente, 1 anta ribalta e 1 cassetto interno, piedini altezza 2 cm regolabili, piede in lamiera laccato nero opaco. Finitura gofrata nei colori a campionario e finitura foglia argento e foglia oro. Il contenitore necessita il fissaggio a parete. Possibilità di inserire kit illuminazione a led. Il contenitore è predisposto al passaggio interno dei cavi, uscita cavi disposta sulla parte inferiore del vano che appoggia a muro.

Container/tv sideboard in composite wood with 1 hinged door, 1 flap door and 1 inside drawer, h.2 cm adjustable feet, metal base matt black lacquered. Embossed finishing in all colours of our sample catalogue and in gold leaf and silver leaf finishing. The container needs to be fixed on the wall. A lighting system can be inserted (rgb led kit). The container is equipped with internal cable passes, cables exit in the inferior part of the compartment fixed on the wall.



DISTESA

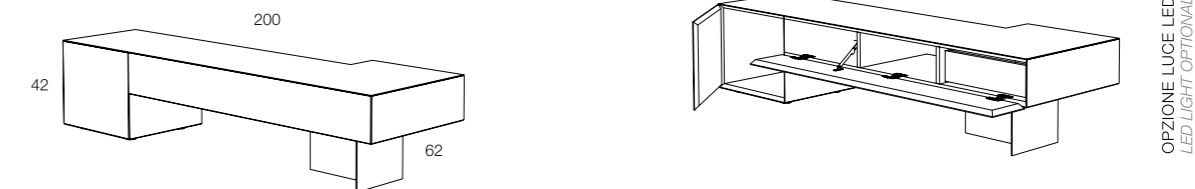

Credenza in agglomerato di legno con 2 ante a ribalta e 1 battente, piedini altezza 2 cm regolabili. Finitura gofrata nei colori a campionario e finitura foglia argento e foglia oro. Il contenitore necessita il fissaggio a parete.
Sideboard in composite wood with 2 flap doors and 1 hinge door, h.2 cm adjustable feet, embossed finishing in all colours of our sample catalogue and in gold leaf and silver leaf finishing. The container needs to be fixed on the wall.

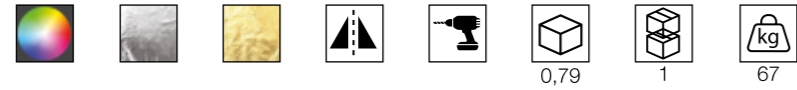

ADAGIATA



Comodino in agglomerato di legno con 1 anta battente e 1 cassetto esterno, piedini altezza 2 cm regolabili. Finitura gofrata nei colori a campionario e finitura foglia argento e foglia oro. Il contenitore necessita il fissaggio a parete.
Night table in composite wood with 1 hinge door and 1 external drawer, h.2 cm adjustable feet. Embossed finishing in all colours of our sample catalogue and in gold leaf and silver leaf finishing. The container needs to be fixed on the wall.

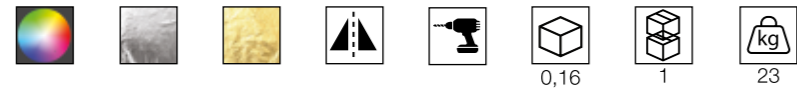

APPOGGIATA



Comodino in agglomerato di legno con 1 anta battente e 1 cassetto interno, piedini altezza 2 cm regolabili. Finitura gofrata nei colori a campionario e finitura foglia argento e foglia oro. Il contenitore necessita il fissaggio a parete.
Night table in composite wood with 1 hinge door and 1 internal drawer, h.2 cm adjustable feet. Embossed finishing in all colours of our sample catalogue and in gold leaf and silver leaf finishing. The container needs to be fixed on the wall.

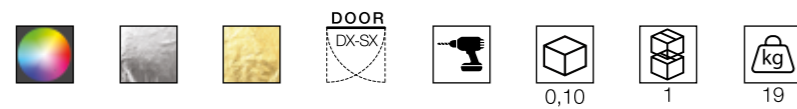

ACCUCCIATA



Specchio circolare di grandi dimensioni in metallo. Finitura gofrata nei colori a campionario o finitura foglia argento e foglia oro. Possibilità' di inserire kit illuminazione a led.
Circular mirror of big diameter in metal. Embossed finishing in all colours of our sample catalogue, in gold leaf and silver leaf finishing. A lighting system can be inserted (led kit)



FULL MOON 130

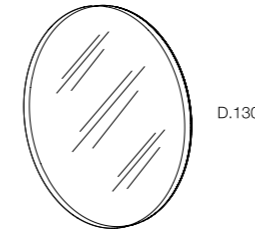

OPZIONE LUCE LED
LED LIGHT OPTIONAL

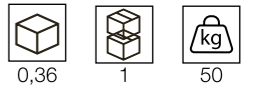

FULL MOON 150

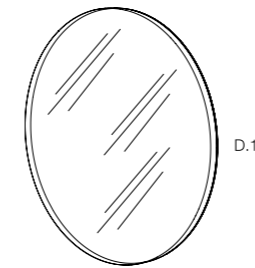

OPZIONE LUCE LED
LED LIGHT OPTIONAL

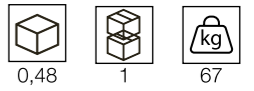

Contenitore pensile in agglomerato di legno, 1 anta battente e 1 ripiano spostabile in cristallo extra - chiaro. Finitura gofrata nei colori a campionario.
Wall case in composite wood, 1 hinged door and 1 extra-clear crystal glass removable shelf. Embossed finishing in all colours of our sample catalogue.

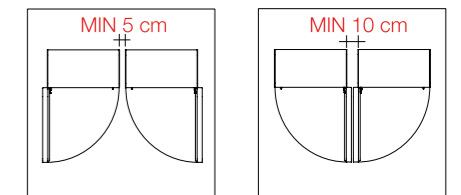
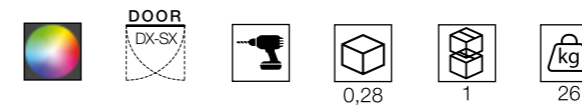

GESSOLINA
PENSILE / HANGING CONTAINER

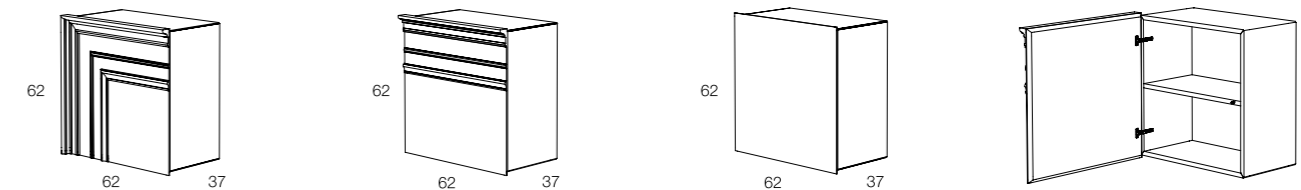

Credenza in agglomerato di legno a 2 ante battenti (esterne) e 2 cassetti (centrali), 2 ripiani spostabili in cristallo extra-chiaro. Finitura gofrata nei colori a campionario. Piedini altezza 10 cm in metallo satinato colore ottone verniciato o nichel.
Sideboard in composite wood with 2 hinged doors (external) and 2 drawers (central), 2 removable shelves in extra-clear crystal-glass. Embossed finishing in all colours of our sample catalogue. h.10 cm. feet in satin metal brass or nickel colour.

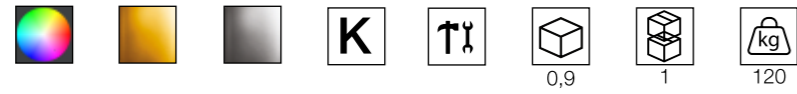

GESSOLINA
CREDENZA / SIDEBOARD

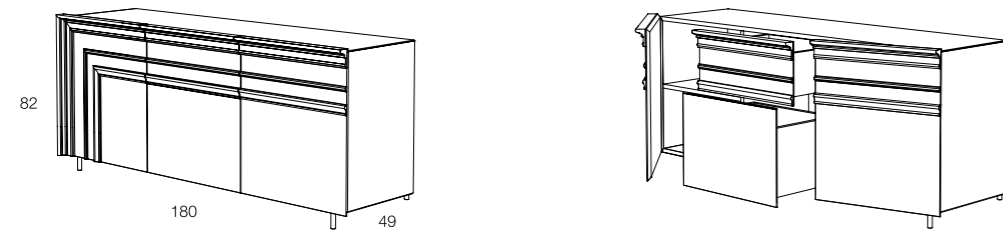

Madia in agglomerato di legno a 2 ante battenti, 2 cassetti (interni), 5 ripiani interni di cui 4 spostabili. Finitura gofrata nei colori a campionario. Piedini altezza 10 cm in metallo satinato colore ottone verniciato o nichel.
High container in composite wood with 2 hinged doors, 2 drawers (inside), 5 internal shelves 4 of them removable, embossed finishing in all colours of our sample catalogue. h.10 cm. feet in satin metal brass or nickel colour.



GESSOLINA
MADIA / HIGH CONTAINER

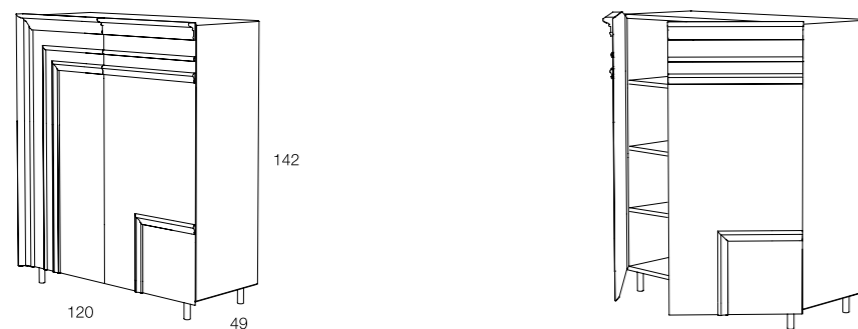

Contenitori (credenza / madia) ad ante battenti in agglomerato di legno, piedini altezza 2 cm regolabili. Finitura gofrata nei colori a campionario. Elemento decorativo (king) in fusione di metallo colore nichel nero lucido.
Storage units (sideboard/high sideboard) with hinged doors in composite wood, h.2 cm adjustable feet. Embossed finishing in all colours of our sample catalogue. Decorative element (king) in metal fusion colour bright black nickel.



KING 90

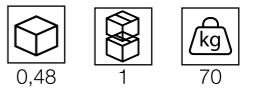
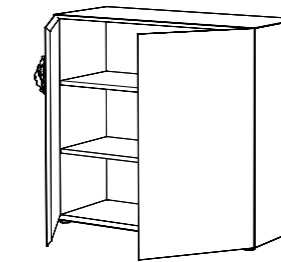
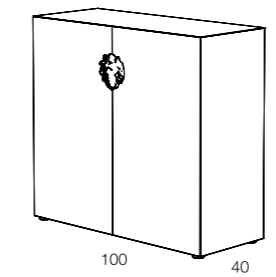

KING 125

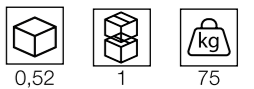
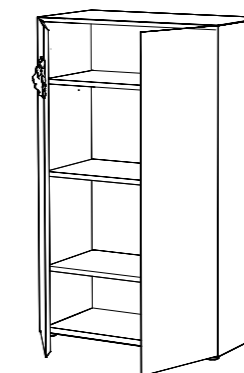
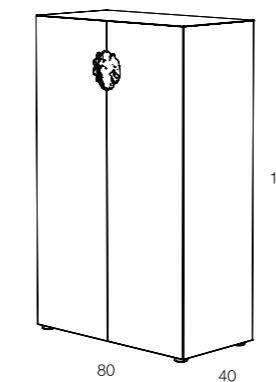

M K

Contenitori credenza con ante battenti (3 - 4 - 5) in agglomerato di legno con piano d'appoggio a specchio, lavorazione a 45° sui 4 lati, piedini altezza 2 cm regolabili. Finitura gofrata nei colori a campionario.

Sideboards with hinged doors (3-4-5) in composite wood with mirrored top, with a 45° working finish on 4 sides, h.2 cm adjustable feet. Embossed finishing in all colours of our sample catalogue.

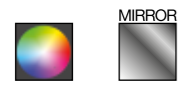

KM 3

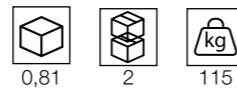
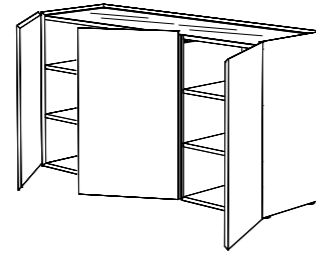
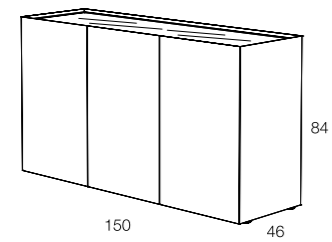

KM 4

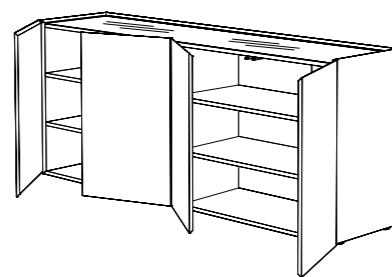
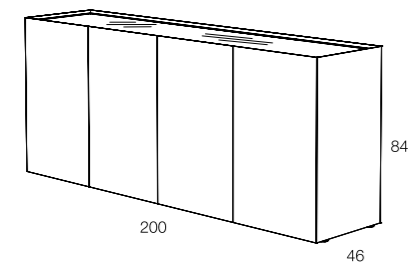

KM 5

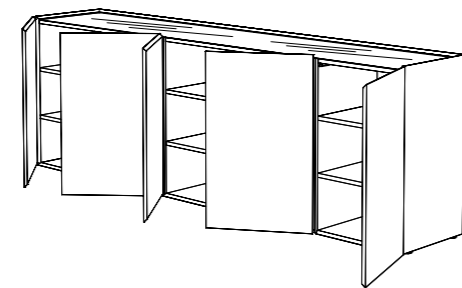
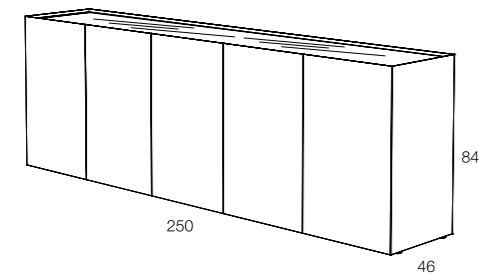

LADY & MAN

Contenitori in agglomerato di legno a 2 ante battenti scultoree, piedini altezza 2 cm regolabili.

Finitura gofrata nei colori a campionario. Disponibile in versione armadio con tubo appendiabiti (profondità 63 cm) e versione contenitore a ripiani spostabili (profondità 47).

Containers in composite wood with 2 sculptural hinged doors, h.2 cm adjustable feet.

Embossed finishing in all colours of our sample catalogue. Available as cabinet version with 1 bar for clothes hanger (depth 63 cm) and as container with removable shelves (depth 47)

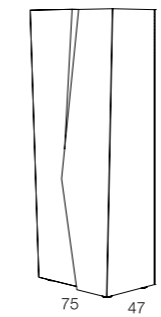

LADY 44

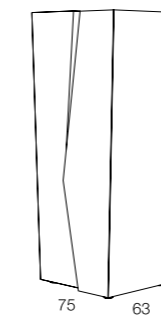
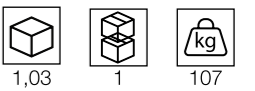
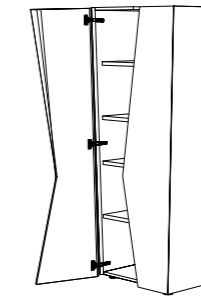

LADY 60

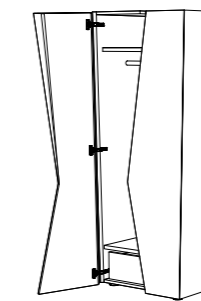

OPZIONE: KIT 2 RIPIANI
KIT 1 CASSETTO (MAX 4)
OPTIONAL: KIT 2 SHELVES
KIT 1 DRAWER (MAX 4)

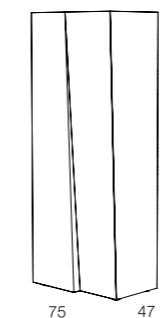
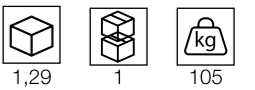

MAN 44

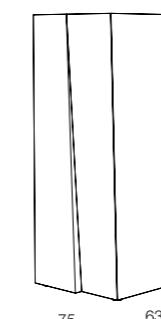
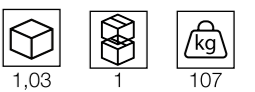
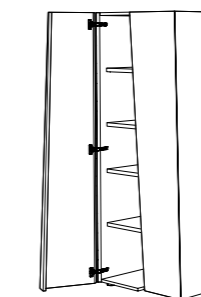

MAN 60

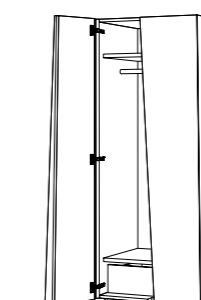

OPZIONE: KIT 2 RIPIANI
KIT 1 CASSETTO (MAX 4)
OPTIONAL: KIT 2 SHELVES
KIT 1 DRAWER (MAX 4)

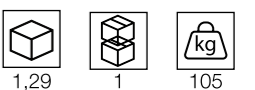

METEORE

Appendiabito a parete in sasso di arenaria.
Wall clothes stand in sandstone.

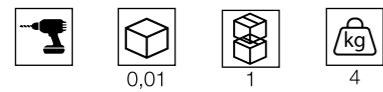

0,01 1 4

METEORE

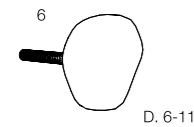

SET DI 5 SASSI
 SET 5 STONES

PEPITE

Appendiabito a parete in fusione di ottone, finitura ottone lucido o cromo lucido.
Wall clothes stand in brass fusion, finish bright brass or polished chrome.



0,01 1 3

PEPITE

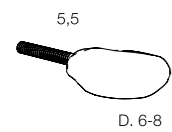

SET DI 3 PEPITE
 SET 3 NUGGETS

MI MI

Coppia di mani in fusione di alluminio con guanti da lavoro in dotazione.
Pair of hands in aluminium fusion, equipped with work gloves.

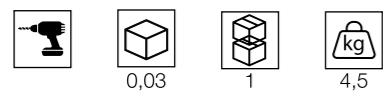

0,03 1 4,5

COPPIA DX - SX
 RIGHT AND LEFT PAIR

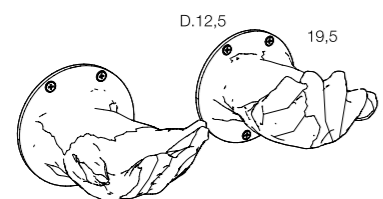

NYC

Cassettiera con distanziali componibile in agglomerato di legno, lavorazione a 45° sui 4 lati, piedini altezza 2 cm regolabili.
 Finitura gofrata nei colori a campionario. Cassettiera e distanziali possono avere colori diversi.
*Modular chest of drawers with spacers in composite wood, with a 45° working finish on 4 sides, h.2 cm adjustable feet.
 Embossed finishing in all colours of our sample catalogue, the drawer unit and the spacers can also have different colours.*



NYC 7

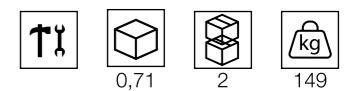
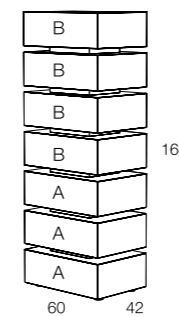

0,71 2 149

NYC 6

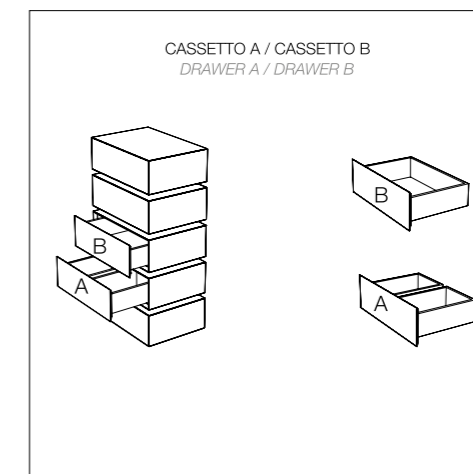
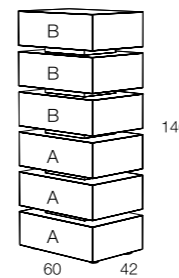

0,49 2 127

NYC 5

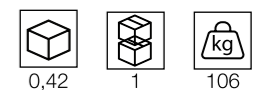
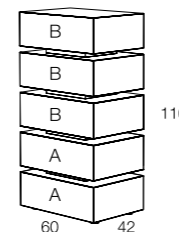

0,42 1 106

NYC 4

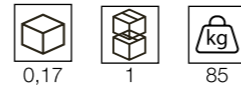
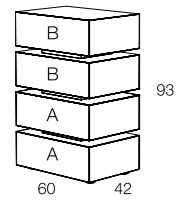

NYC 3

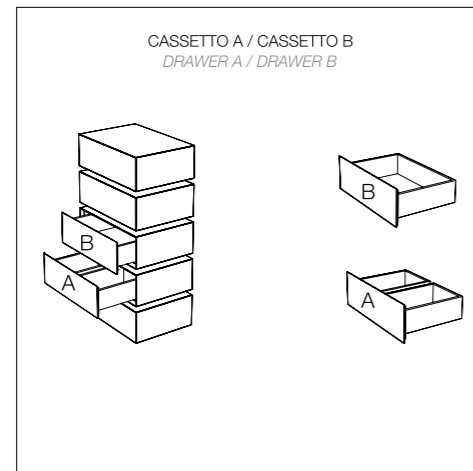
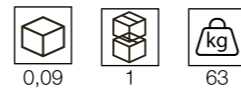
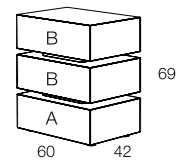

NYC 2

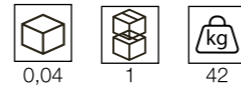
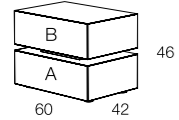

POINTA

Libreria autoportante in agglomerato di legno caratterizzata da rombi girevoli, tiranti in metallo cromato. I rombi sui ripiani si possono agevolmente rimuovere e successivamente riposizionare (senza l'utilizzo di attrezzi). Finitura gofrata nei colori a campionario. Ripiani e rombi possono avere colori diversi.
Free-standing bookcase in composite wood characterized by revolving rhombus, rods in chromed metal. The rhombus pieces on the shelves can be easily removed and then placed (without using tools). Embossed finishing in all colours of our sample catalogue, shelves and rhombus can have different colours.

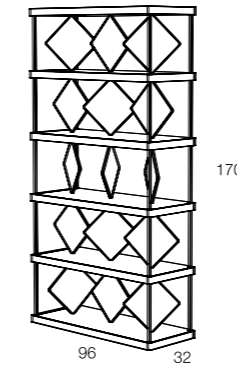
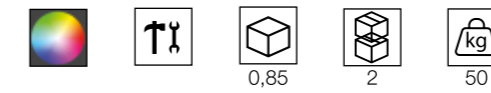

PISA

Cassettiera con distanziali in agglomerato di legno composta da 7 cassetti, lavorazione a 45° sui 4 lati, piedini altezza 2 cm regolabili. Finitura gofrata nei colori a campionario. Cassettiera e distanziali possono avere colori diversi.
Modular chest of drawers with spacers in composite wood, composed by 7 drawers, with a 45° working finish on 4 sides, h.2 cm adjustable feet. Embossed finishing in all colours of our sample catalogue, the drawer unit and the spacers can also have different colours.



PISA

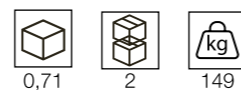
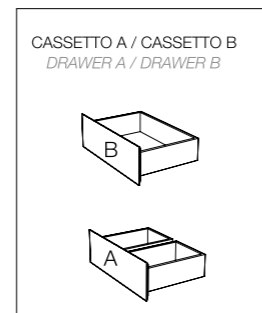
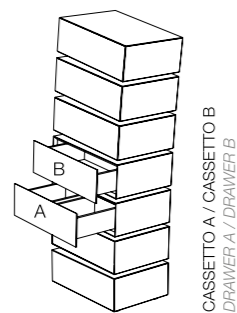
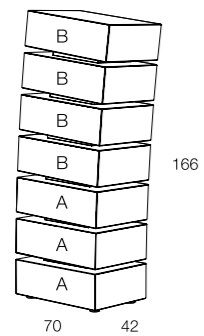

PUNTO

Specchi circolari a parete in metallo. Finitura gofrata colore antracite o finitura foglia argento e foglia oro.
Wall circular mirrors in metal. Embossed finishing colour antracite or in gold leaf and silver leaf finishing.



PUNTO

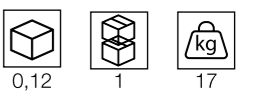
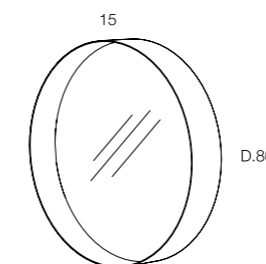
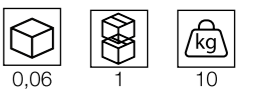
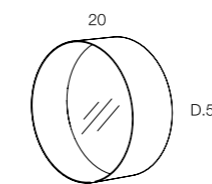
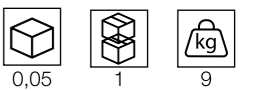
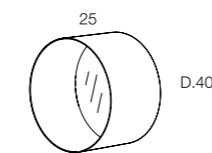

Specchi quadrangolari a parete in metallo. Finitura gofrata colore antracite.
Wall square/rectangular mirrors in metal. Embossed finishing antracite colour.



BARRA

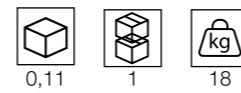
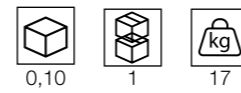
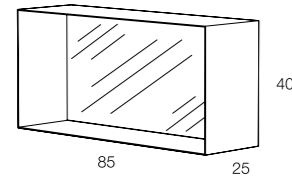
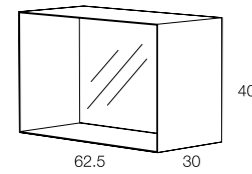

TASTO

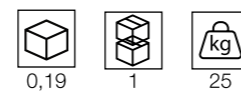
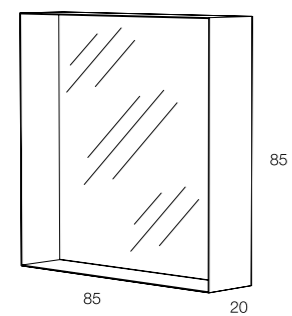
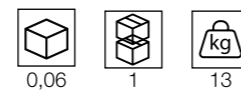
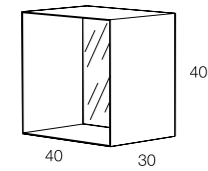

Contenitore autoportante in agglomerato di legno con anta battente sagomata, 5 ripiani di cui 2 spostabili. Lavorazione a 45° sui 4 lati, piedini altezza 2 cm regolabili. Finitura gofrata nei colori a campionario. Inserto in metallo disponibile nei colori a campionario, finitura opaco (non gofrato).

Free-standing column container in composite wood with shaped hinged door, 5 shelves 2 of which removable. With a 45° finish on 4 sides, h.2 cm. adjustable feet. Embossed finishing in all colours of our sample catalogue, metal insert available in all colours of our sample catalogue, matt finish (not embossed)

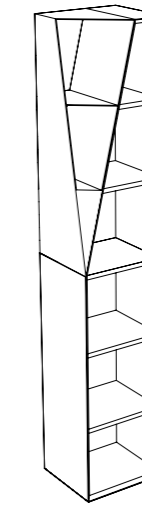
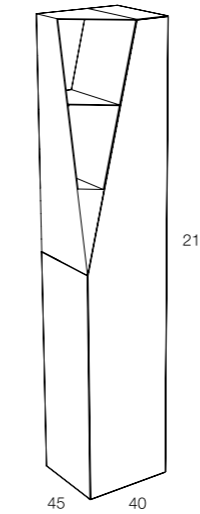
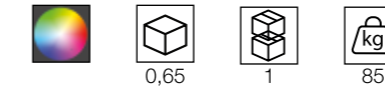

Contenitore autoportante in agglomerato di legno con anta sagomata, lavorazione a 45° sui 4 lati, 5 ripiani interni di cui 2 spostabili, piedini altezza 2 cm regolabili. Finitura gofrata nei colori a campionario.

Il vano a giorno puo' essere in finitura gofrata nei colori a campionario, in finitura foglia argento e foglia oro.

Free-standing column container in composite wood with shaped door, with a 45° finish on 4 sides, 5 internal shelves 2 of them removable, h.2 cm. adjustable feet, embossed finishing in all colours of our sample catalogue.

The hollow/open compartment can be in all colours of our sample catalogue, in gold leaf and silver leaf finishing.

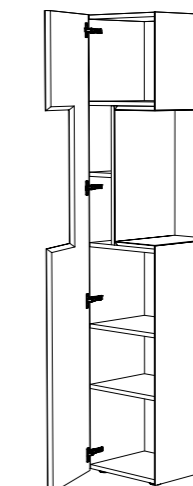
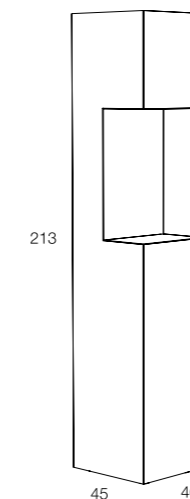

Contenitore pensile in agglomerato di legno con 1 anta battente in poliuretano rigido e un ripiano spostabile.
 Finitura gofrata nei colori a campionario.
Wall case in composite wood with 1 hinged door in rigid polyurethane and 1 removable shelf.
Embossed finishing in all colours of our sample catalogue.

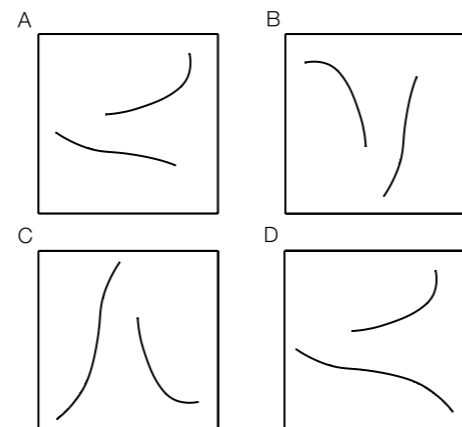

SPECIFICARE IL TIPO DI ANTA DESIDERATO
 SPECIFY THE DESIRED DOOR TYPE

ONDA 33

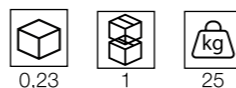
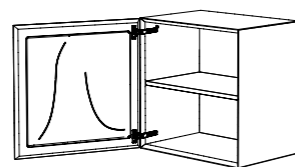
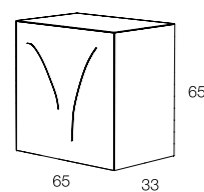

ONDA 44

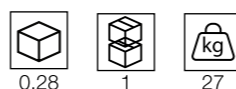
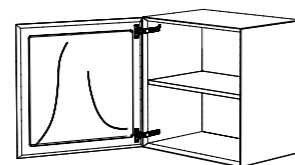
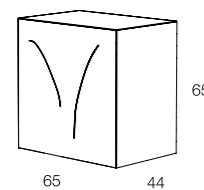

Contenitore autoportante in agglomerato di legno con 2 ante battenti indipendenti, 5 ripiani interni di cui 3 spostabili e 1 cassetto interno, piedini altezza 2 cm regolabili. Possibilita' di apertura ante dx o sx.
 Finitura gofrata nei colori a campionario.
Free-standing column container in composite wood with 2 independent hinged doors, 5 internal shelves 3 of them removable and 1 inside drawer, h.2 cm adjustable feet. Possibility of dx right and sx left opening of the doors. Embossed finishing in all colours of our sample catalogue.

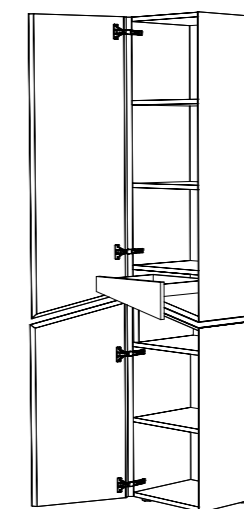
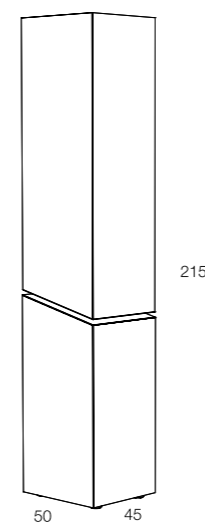
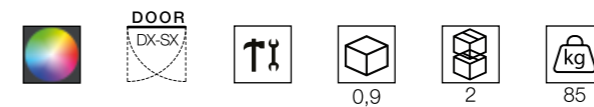

Contenitore pensile a due volumi, in agglomerato di legno con anta vasistas o ribalta e vano con anta battente.
 Finitura gofrata nei colori a campionario. I contenitori possono avere colori diversi.
Wall case formed by 2 elements, in composite wood with vasistas or flap door and compartment with hinged door.
Embossed finishing in all colours of our sample catalogue. The containers can have different colours.

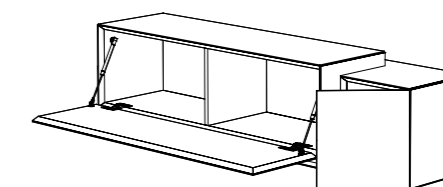
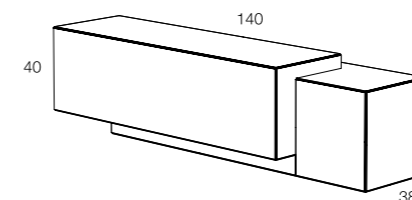
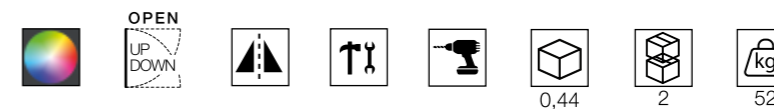

**SPE
CC
HIO**

Specchi a parete con forme irregolari, cornice in agglomerato di legno, finitura gofrata nei colori a campionario. Ampia bisellatura ai bordi della superficie specchiante.

Irregular mirror. The structure can be in embossed finishing in all colours of our sample catalogue. The edge of the mirror has beveled finishing.

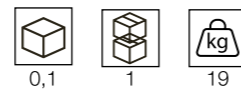
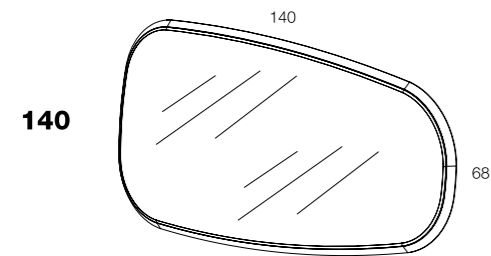
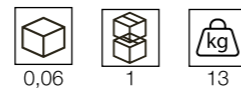
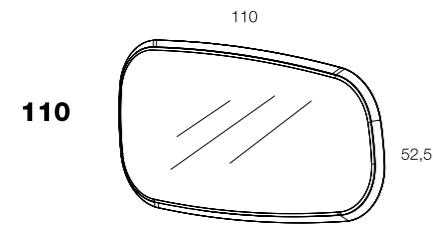
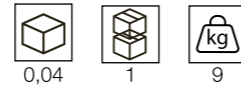
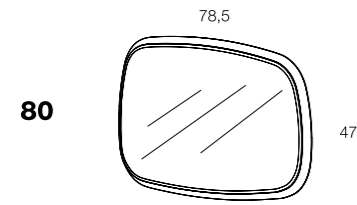

**TEM
PA
NO**

Madia in agglomerato di legno con 2 ante sagomate, lavorazione a 45° sui 4 lati, tre ripiani spostabili in cristallo extra-chiaro, schienale interno a specchio. Contenitore in finitura gofrata nei colori a campionario, base in metallo colore antracite in finitura gofrata.

High container in composite wood with 2 shaped doors, with a 45° finish on 4 sides, 3 removable shelves in extra-clear crystal glass, inside mirrored back. Container in embossed finishing in all colours of our sample catalogue, base in embossed lacquered antracite metal.

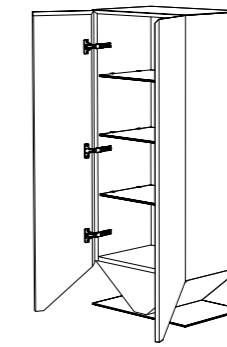
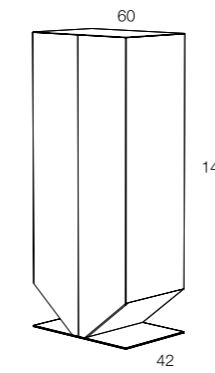
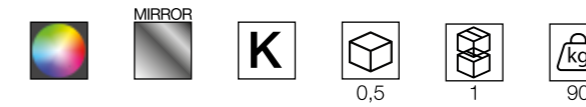

**DU
E
DI
&
QUA
TTRO
DI**

Contenitore pensile in agglomerato di legno, orizzontale e verticale con anta (vasistas / ribalta / battente). Finitura gofrata nei colori a campionario.

Wall case in composite wood, horizontal and vertical with door (vasistas / flap /hinged door). Embossed finishing in all colours of our sample catalogue.



DUEDI

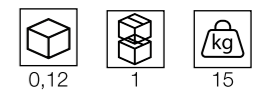
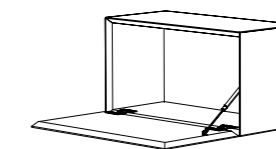
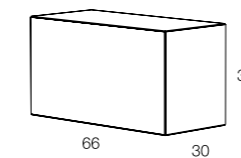

QUATTRODI

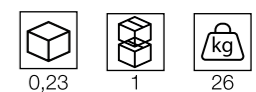
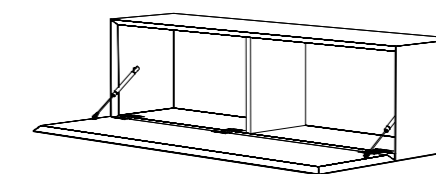
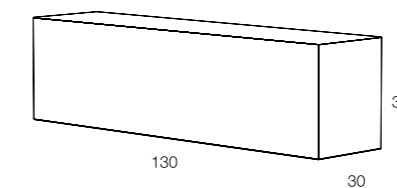

TR EDI

Contenitore pensile in agglomerato di legno, orizzontale e verticale con anta sagomata (vasistas / ribalta / battente). Finitura goffrata nei colori a campionario. Il vano puo' essere in finitura goffrata nei colori a campionario, in finitura foglia argento e foglia oro.

Wall case in composite wood, horizontal and vertical with shaped door (vasistas / flap /hinged door). Embossed finishing in all colours of our sample catalogue. The hollow can be in embossed finishing in all colours of our sample catalogue, in gold leaf and silver leaf finishing.



TREDI ORIZZONTALE / HORIZONTAL

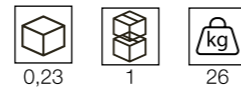
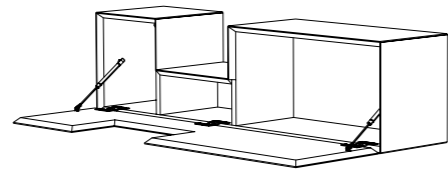
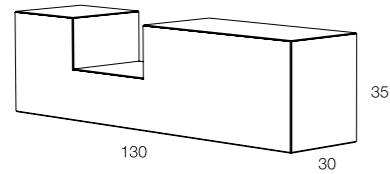

TREDI VERTICALE / VERTICAL

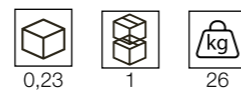
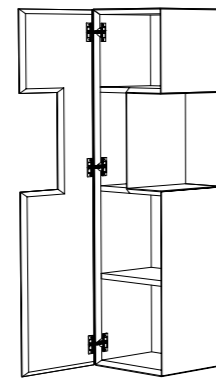
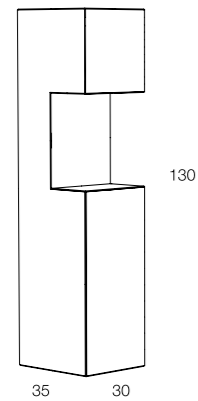

TR RI

Mensola / contenitore a giorno in agglomerato di legno, finitura goffrata nei colori a campionario, inserto ramificato in fusione di ottone.

Shelf/open container in composite wood, embossed finishing in all colours of our sample catalogue, ramified metal insert in brass fusion.



TRI 1

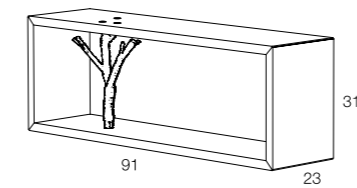

TRI 2

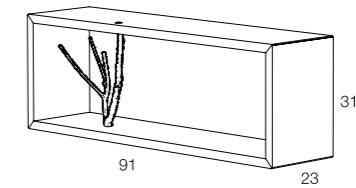

TRI 3

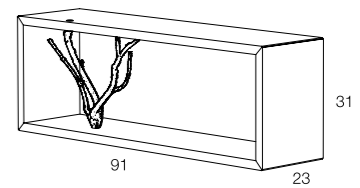

TU BI

Tavolo in tubolare di ferro, telaio disponibile in colore nero finitura opaca, puntali in ottone lucido o nichel lucido, piani in cristallo extra - chiaro o fumè grigio europa.

Table in iron tubular, structure available in black matt finish, toppers in bright brass or bright nickel, tops in extra-clear crystal glass or grey fume' europa.

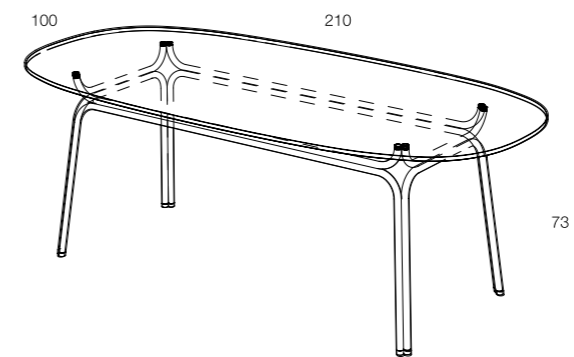

Specchi con cornice in metallo, caratterizzati da forme richiamanti finestre ad arco. Finitura gofrata nei colori a campionario e finitura foglia argento e foglia oro.

Mirrors with metal frame, characterized by a shape similar to ancient arched windows. Embossed finishing in all colours of our sample catalogue and silver leaf and gold leaf finishing.

WINDOWS
CORNICE METALLO / METAL FRAME

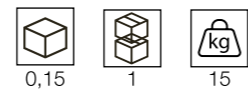
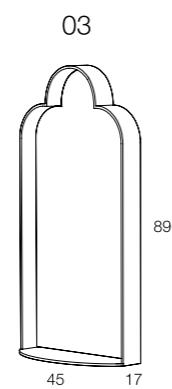
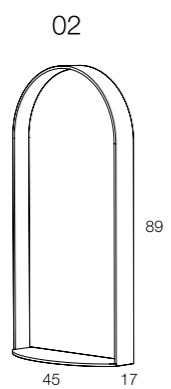
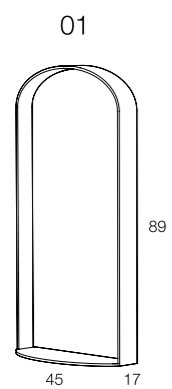

Specchi con cornice in agglomerato di legno, caratterizzati da forme richiamanti finestre ad arco. Finitura gofrata nei colori a campionario

Mirrors with frame in composite wood, characterized by a shape similar to ancient arched windows. Embossed finishing in all colours of our sample catalogue.

WINDOWS
CORNICE LEGNO / WOOD FRAME

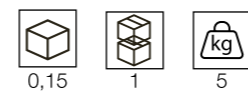
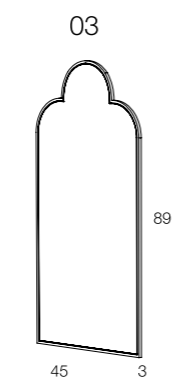
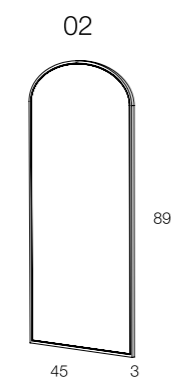
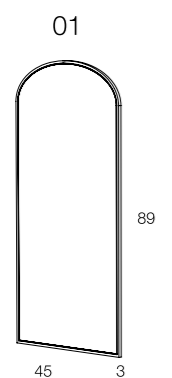

A.
D.
&
GRA
PH
ICS

STUDIO14

PRI
NT
IN
G

ARTI GRAFICHE
MASPERO FONTANA
GENNAIO 2021

minottiitalia

ADION S.R.L.
VIALE REPUBBLICA, 140
22060 – CABIATE
+39 031 769 251
INFO@MINOTTITALIA.IT
WWW.MINOTTITALIA.IT

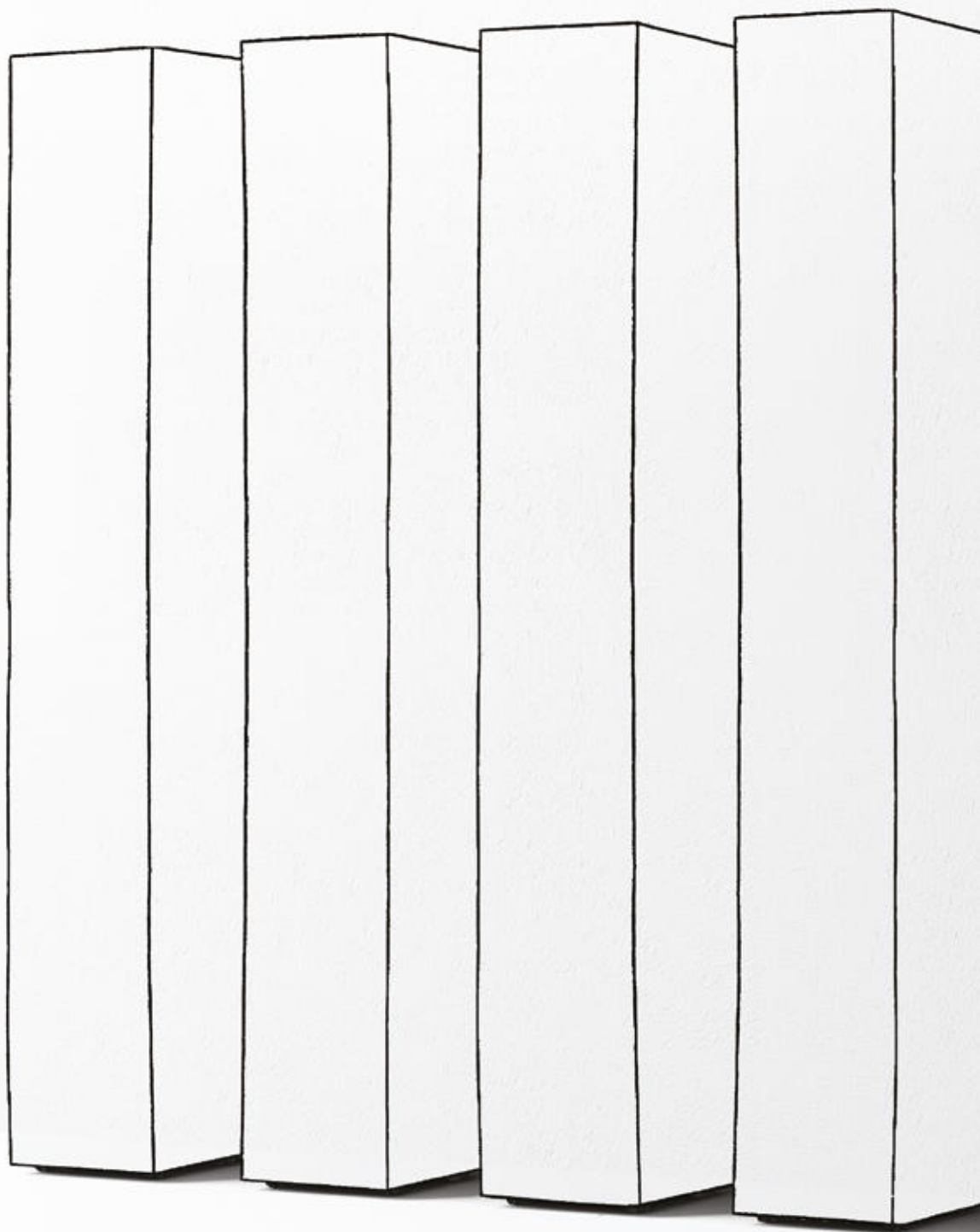

minottiitalia